

EST. 1994



# Weaver Barns *ltd.*

"everyone needs a little structure in their life"

**BUILD  
YOUR  
DREAM SPACE**



www.**weaverbarns**.com

# SHEDS & BARNNS



**Gable** page 20



**Manchester** page 22



**Sugarcreek** page 24



**Craftsman** page 26



**Estate** page 28



**Woodshed** page 30



**Highland** page 32



**Grand Junction** page 34



**Studio** page 36



**Skür** page 38



**Easton** page 40



**Shed Addition** page 42

# BACKYARD BASICS



**Jackson** page 46



**Addison** page 47



**New Haven** page 48



**Camden** page 49

# BACKYARD LIVING



**Laredo** page 51



**Timber Ridge** page 52



**Bradford** page 54



**Lakewood** page 56



**Dublin** page 58

# GARAGES



**Gable Garage** page 64



**Workshop** page 66



**Classic** page 68



**Heritage** page 70



**Rockport** page 72



**Willow Creek** page 74



**Cascade** page 76



**Dutch Garage** page 78



**Dutch Barn** page 80

# CABINS



**Frontier** page 82



**Aspen** page 84

# HOMES



**Rocky Ridge** page 87



**Cedar Brooke** page 88



**Cedar Brooke** page 89



**Timber Lodge** page 90



**Grand Lake** page 91

*Check out our home brochures for more information!*

# DESIGNING YOUR PERFECT SPACE

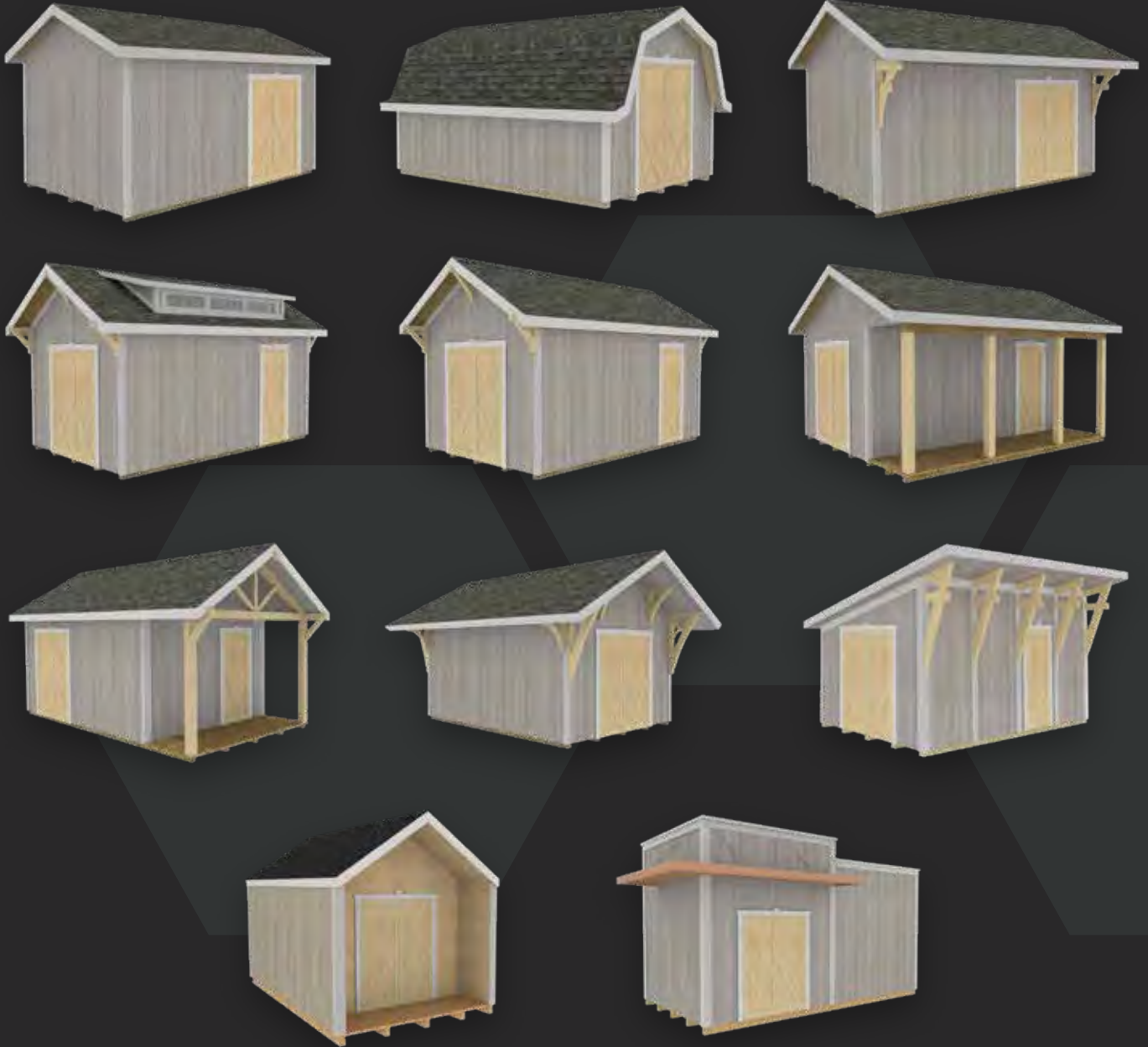

CHOOSE A BASE DESIGN

**BASIC**

All of our products can be configured the way you want it. We make this easy, with options and accessories to make it yours.



MAKE IT YOURS

**PERSONALIZED**



# WELCOME

Since 1994 Weaver Barns has been building two things—structures and a reputation for unmatched quality. We strive to provide the best in everything we do, from customer service to manufacturing to installation. Quite simply, we provide you an excellent product that you and your family will enjoy for many years to come.



**Weaver Barns** *ltd.*  
"everyone needs a little structure in their life"











# DESIGN STYLES

To find a style that best fits your standards, we have a large variety of features for you to choose from. These styles are all unique and customizable, so you can find one that fits best into your space. Unlike other brands, our designs are not only based on appearance, but also on their functionality and durability. If you aren't sure what style will work best for your structure, our team is always eager to help guide you by giving recommendations specific to you and what you're looking for.





# OLD WORLD GARDEN FARMS

Weaver Barns gives flexibility, the ability to customize, and most importantly, quality, to each customer we serve. Customers Jim and Mary from *Old World Garden Farms* fell in love with our designs and their ability to customize our structures to work specifically for their needs. Featured on this page are a few of the structures we have built with them. You can find more features on these building projects at their home and garden website. [oldworldgardenfarms.com](http://oldworldgardenfarms.com)





# STRENGTH

A No Compromise Approach to Quality

At Weaver Barns, our culture is quality. Every aspect of the projects we do is done right. We care about building something that will last. We understand that our customers need a space that will stand the test of time. From custom milling our floor boards to buying premium grade lumber, to using the finest materials we can source, we do not just build a shed, we build the Weaver way.



# FOUNDATION TYPES

## BLOCK SITE PREP

\*Not Recommended For Grades Exceeding 8"

Place 8" x 16" x 4" cement blocks underneath the skids. Every skid needs a block at the front and back and then additional blocks need to be placed in the middle spaced not more than 6' apart.

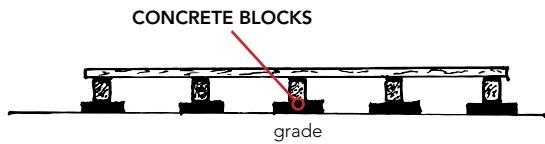

## LIMESTONE PAD

\*The Most Popular Choice For Sheds

Spread 4" of #57 limestone in a level pad 12" beyond the width and the length of the building on all sides. Also, you may want to use a 4 x 4 as an edge as shown in the example below.

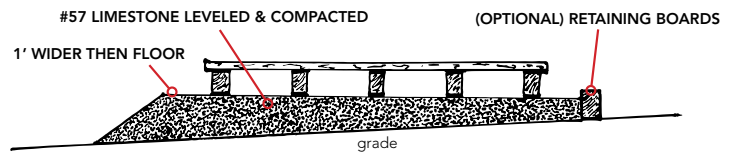

## CONCRETE FOUNDATIONS

Pour the pad 1/2" less than the dimensions of the building. We attached treated plates to the bottom of the walls protecting the walls from moisture and rot. These bottom plates are fastened to the concrete pad with anchors or bolts.

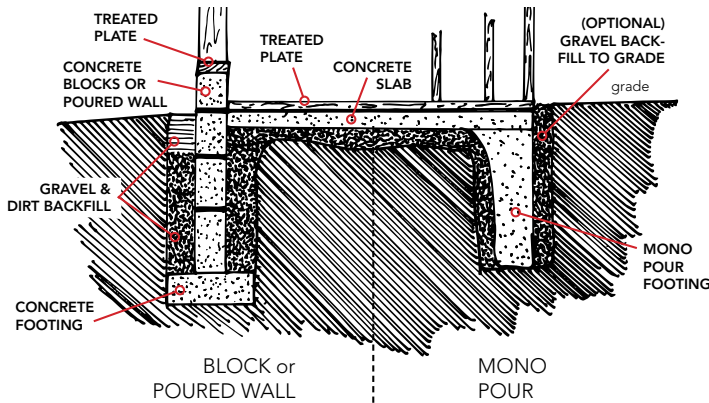

## POST PLATFORM FOUNDATION

Use treated posts. Dig the post holes 32"- 42" deep. Place post pad or concrete in the bottom of the hole. Insert posts. Fasten cross beam joists with bolts to posts as shown making sure that the entire structure is square.

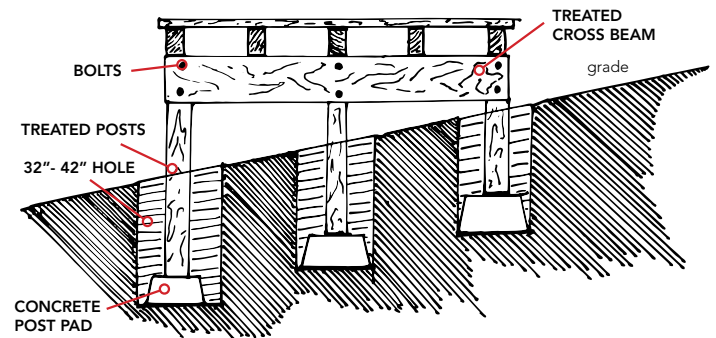

## SHED ON SLAB

To attach a shed to a slab, have your concrete contractor add a 4" reinforced curb. This will keep water from entering the structure.

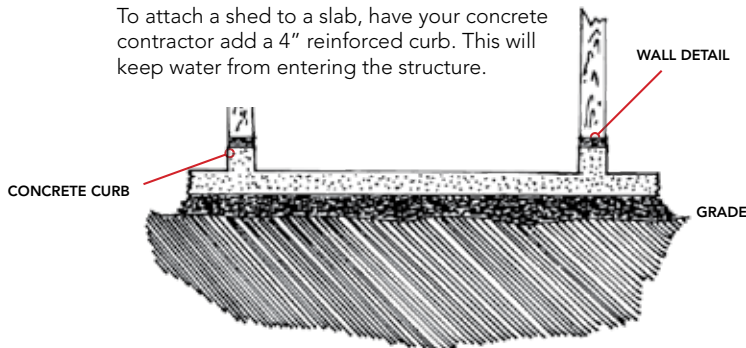

## SKID PLACEMENT

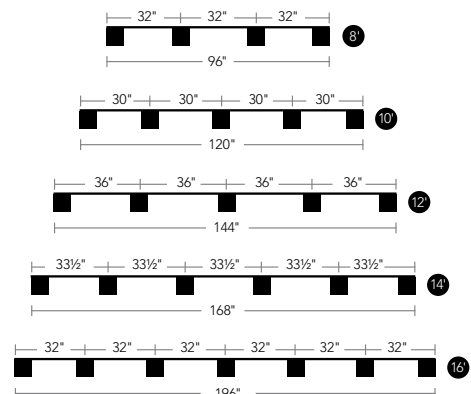

# OUR PRICES INCLUDE DELIVERY

WE DELIVER TO YOUR SITE

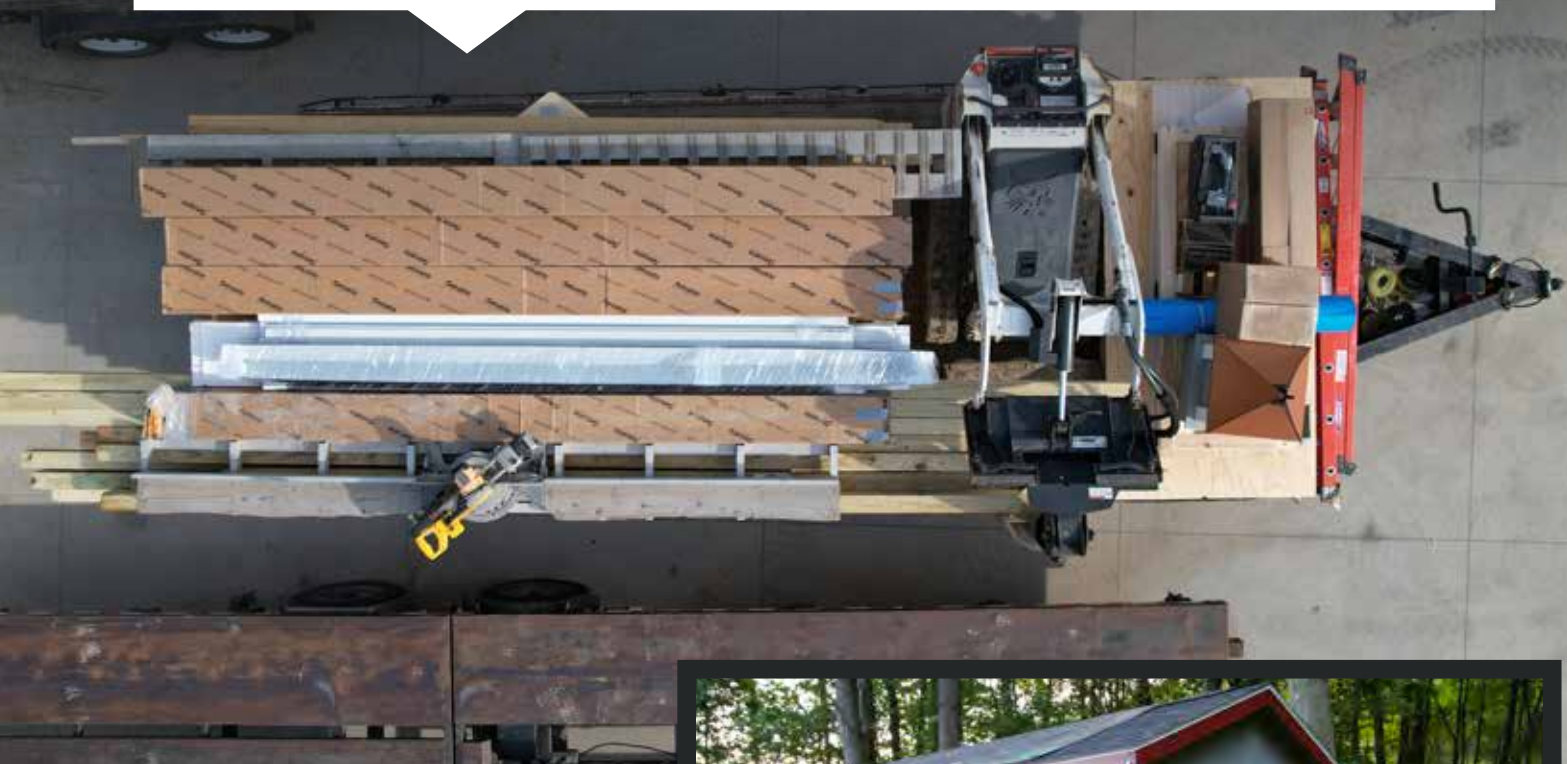

**PREBUILT &  
DELIVERED**



**— OR —**

**DELIVERED &  
BUILT ON SITE**



# DAY OF DELIVERY

BEYOND FREE DISTANCE APPLIES  
\$1.00 Per Foot Carry Charge

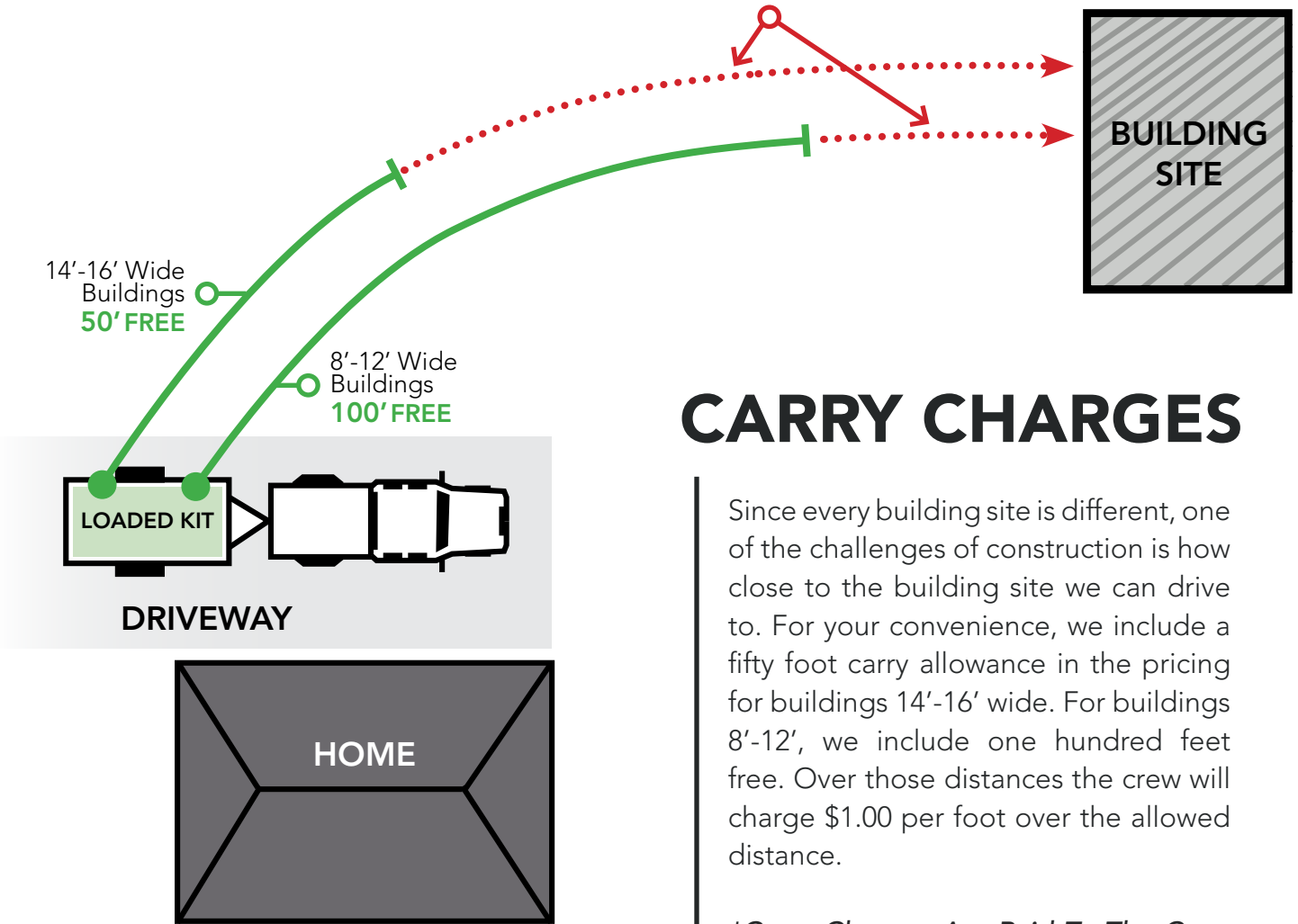

## CARRY CHARGES

Since every building site is different, one of the challenges of construction is how close to the building site we can drive to. For your convenience, we include a fifty foot carry allowance in the pricing for buildings 14'-16' wide. For buildings 8'-12', we include one hundred feet free. Over those distances the crew will charge \$1.00 per foot over the allowed distance.

*\*Carry Charges Are Paid To The Crew Directly*

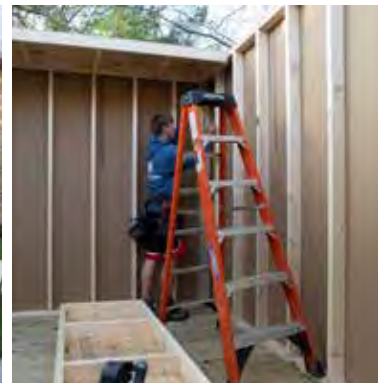

# WHAT SIZE IS RIGHT?

When determining what size is right for your structure, we encourage you to talk to one of our qualified team members to figure out what works best for you. There are a lot of decisions that go into creating a structure, and we want to make that process as easy as possible for you, whether it's a custom garage or even a shed.

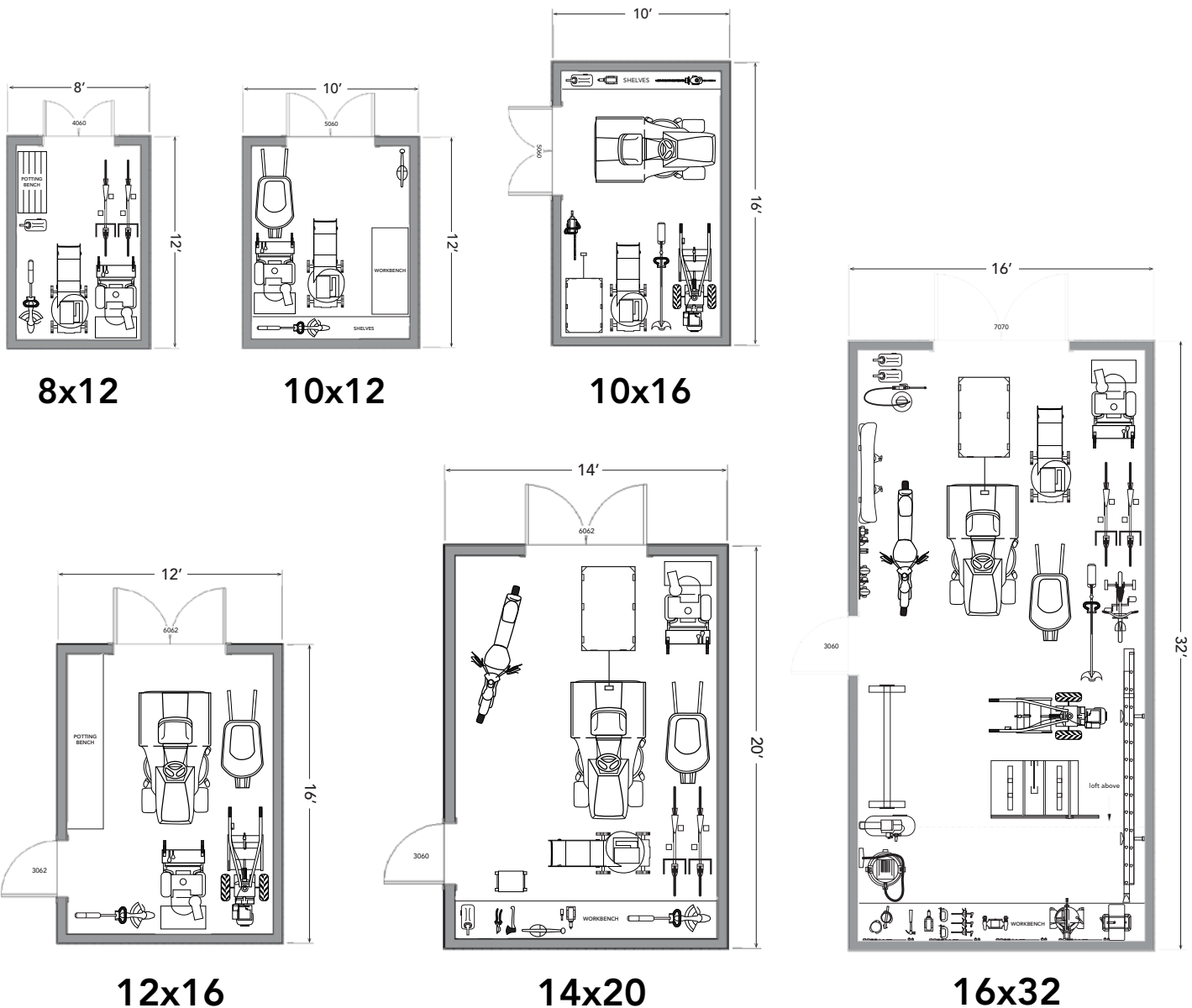



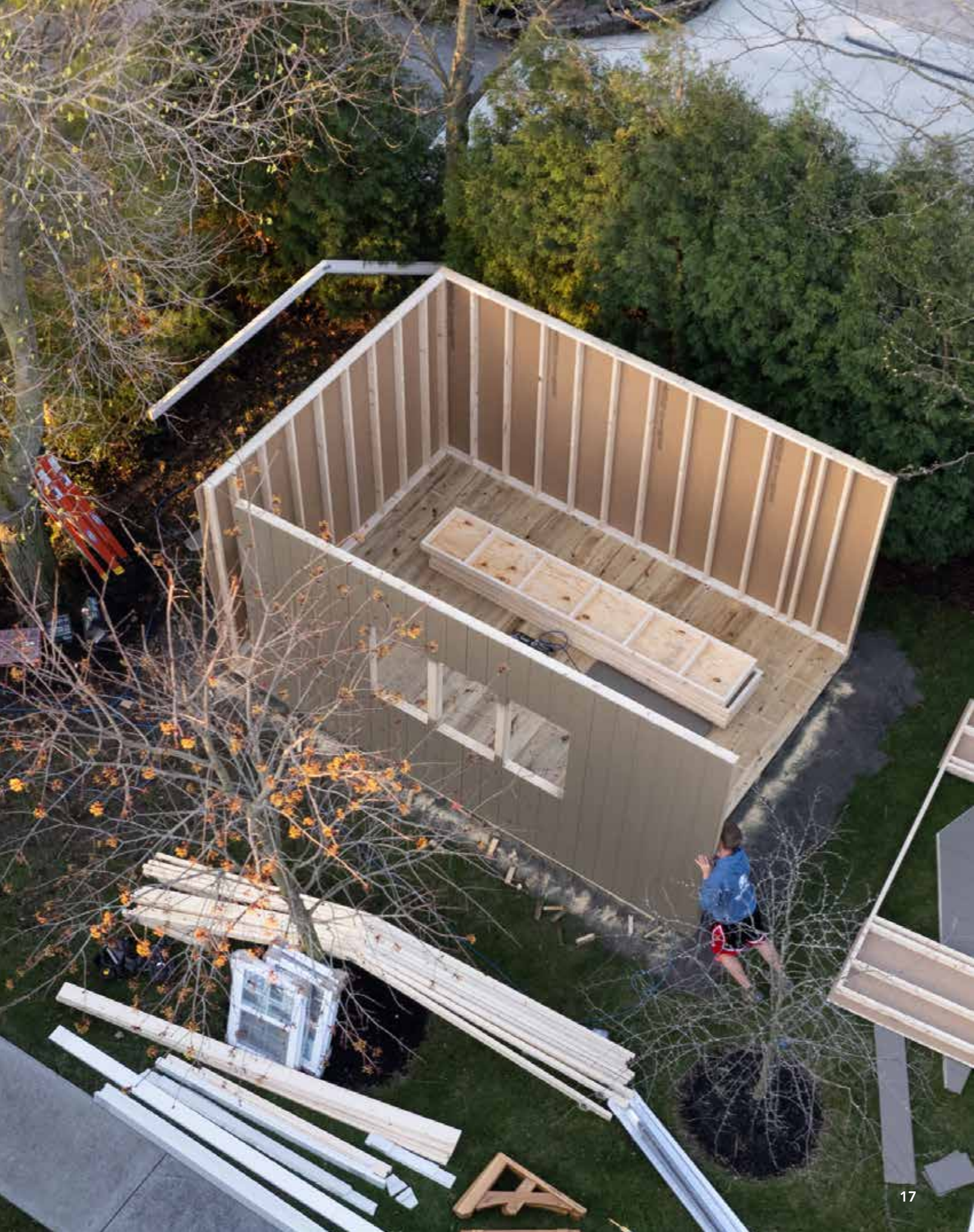



# SUPERIOR FEATURES

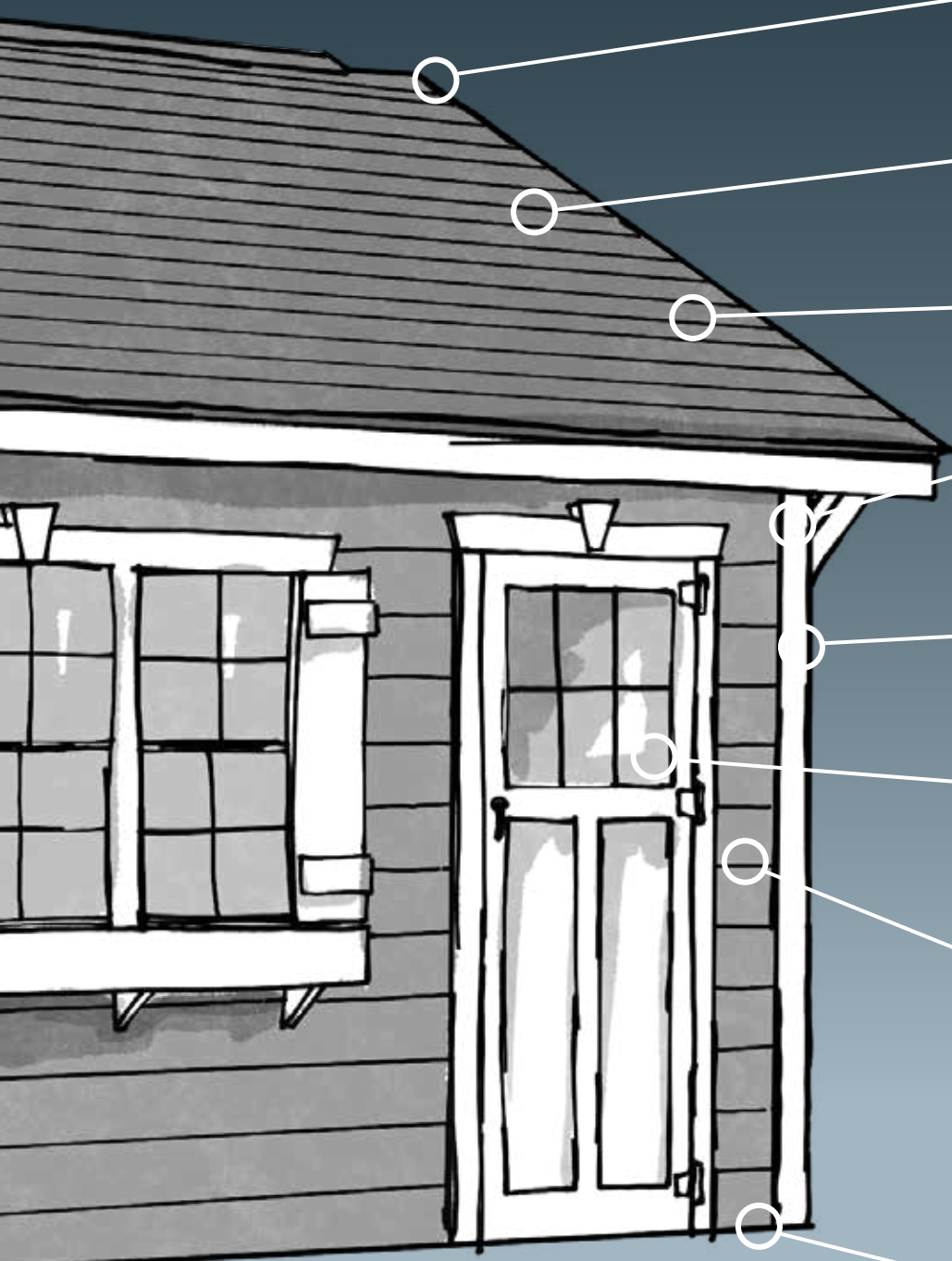

## COOLER

Engineered Ventilation System  
EXTENDS SHED LIFESPAN

## ROOFING FELT

Extra Moisture Protection  
EXTENDS SHED LIFESPAN

## STRONGER ROOF

Superior Plywood Strength  
ROOF SHEATHING

## WEATHER PROTECTED

ROT RESISTANT TRIM PROTECTS  
FROM MOISTURE DAMAGE

## MORE STORAGE

7' 3 1/2" High  
HIGHER WALLS

## STURDY DOORS

Triple Layer Door (with drop rods)  
SOLID CEDAR

## SUPERIOR FRAMING

Premium Grade  
BETTER LUMBER

2X6 Double Door Headers  
2x4 Double Stud Door Frames  
STRONGER DOOR FRAMES

16 Inches On Center  
STRONGER STUDS & RAFTERS

## TOUGHER FLOOR

Rated 1,000 lb. per sq. ft. (pressure treated)  
HEAVIEST FLOOR in the Industry

STANDARD ON SIGNATURE SERIES

# SIDING CHOICES

## LP LAP SIDING

- 50 YEAR LIMITED WARRANTY
- Natural Wood Grain Texture
- 100% Clear
- Pre-Primed
- 50 Year Limited Warranty



## VINYL SIDING

- Maintenance Free
- .044 Thickness
- Match Your Home
- CDX Plywood SubSiding



## PINE SIDING

- 1 x 8 Premium Grade Pine Siding
- Exclusive Rough Sawn Finish
- Aesthetically Pleasing
- Tongue & Groove



## BOARD & BATTEN

- 50 YEAR LIMITED WARRANTY
- Natural Wood Grain Texture
- 100% Clear
- Pre-Primed
- 50 Year Limited Warranty



## DURATEMP SIDING

- 50 YEAR LIMITED WARRANTY
- Natural Wood Grain Texture
- 100% Clear
- Pre-Primed
- 50 Year Limited Warranty



## SMARTSIDE SIDING

- 50 YEAR LIMITED WARRANTY
- Natural Wood Grain Texture
- 100% Clear
- Pre-Primed
- 50 Year Limited Warranty





# Gable

Storage • Workshop • Gardening

## OPTIONS

*ON THIS 10x16*

- Estate Gray Dimensional Shingles
- 2' x 3' Windows
- 202TW Doors
- Dark Gray / White



## BASE PRICE UNIT HOW IT'S BUILT



## CONFIGURATION IDEAS



## SIDING CHOICES View Pricing Guide For Current Pricing

<p><b>SMARTSIDE LAP SIDING</b></p> <p>50 YEAR LIMITED WARRANTY</p> <ul style="list-style-type: none"> <li>Natural Wood Grain Texture</li> <li>100% Clear</li> <li>Pre-Primed</li> <li>50 Year Limited Warranty</li> </ul> <p><b>LP</b></p>	<p><b>VINYL SIDING</b></p> <ul style="list-style-type: none"> <li>Maintenance Free</li> <li>.044 Thickness</li> <li>Match Your Home</li> <li>CDX Plywood Subsiding</li> </ul> <p><b>ProVia</b> HEARTTECH</p>	<p><b>PINE SIDING</b></p> <ul style="list-style-type: none"> <li>1 x 8 Premium Grade Pine Siding</li> <li>Exclusive Rough Sawn Finish</li> <li>Aesthetically Pleasing</li> <li>Tongue &amp; Groove</li> </ul>	<p><b>BOARD &amp; BATTEN</b></p> <p>50 YEAR LIMITED WARRANTY</p> <ul style="list-style-type: none"> <li>Natural Wood Grain Texture</li> <li>100% Clear</li> <li>Pre-Primed</li> <li>50 Year Limited Warranty</li> </ul> <p><b>LP</b></p>	<p><b>DURATEMP SIDING</b></p> <p>50 YEAR LIMITED WARRANTY</p> <ul style="list-style-type: none"> <li>Natural Wood Grain Texture</li> <li>100% Clear</li> <li>Pre-Primed</li> <li>50 Year Limited Warranty</li> </ul> <p><b>DuraTemp</b></p>	<p><b>SMARTSIDE SIDING</b></p> <p>50 YEAR LIMITED WARRANTY</p> <ul style="list-style-type: none"> <li>Natural Wood Grain Texture</li> <li>100% Clear</li> <li>Pre-Primed</li> <li>50 Year Limited Warranty</li> </ul> <p><b>LP</b></p>
--	--	---	--	---	--



# Manchester

Storage • Horsebarn • Gardening

## OPTIONS

*ON THIS 10x14*

Teak Dimensional Shingles  
5' Sidewall Height  
202TW Doors  
Peak Extension & Bracket  
Bear Beige / Bronze / Pecan



## BASE PRICE UNIT HOW IT'S BUILT



## CONFIGURATION IDEAS



## SIDING CHOICES View Pricing Guide For Current Pricing

<p><b>SMARTSIDE LAP SIDING</b>                  50 YEAR LIMITED WARRANTY                  • Natural Wood Grain Texture                  • 100% Clear                  • Pre-Primed                  • 50 Year Limited Warranty</p>	<p><b>VINYL SIDING</b>                  • Maintenance Free                  • .044 Thickness                  • Match Your Home                  • CDX Plywood Subiding</p>	<p><b>PINE SIDING</b>                  • 1 x 8 Premium Grade Pine Siding                  • Exclusive Rough Sawn Finish                  • Aesthetically Pleasing                  • Tongue &amp; Groove</p>	<p><b>BOARD &amp; BATTEN</b>                  50 YEAR LIMITED WARRANTY                  • Natural Wood Grain Texture                  • 100% Clear                  • Pre-Primed                  • 50 Year Limited Warranty</p>	<p><b>DURATEMP SIDING</b>                  50 YEAR LIMITED WARRANTY                  • Natural Wood Grain Texture                  • 100% Clear                  • Pre-Primed                  • 50 Year Limited Warranty</p>	<p><b>SMARTSIDE SIDING</b>                  50 YEAR LIMITED WARRANTY                  • Natural Wood Grain Texture                  • 100% Clear                  • Pre-Primed                  • 50 Year Limited Warranty</p>
--	---	--	--	---	--



# Sugarcreek

Storage • Pool House • Gardening

## OPTIONS

*ON THIS 10x16*

Driftwood Dimensional Shingles

2' x 3' Windows + Transoms

102TW Doors

Navajo White Traditional Cupola

Buckskin / Navajo White / Bronze





## BASE PRICE UNIT HOW IT'S BUILT



## CONFIGURATION IDEAS



## SIDING CHOICES View Pricing Guide For Current Pricing

<p><b>SMARTSIDE LAP SIDING</b></p> <p>50 YEAR LIMITED WARRANTY</p> <ul style="list-style-type: none"> <li>Natural Wood Grain Texture</li> <li>100% Clear</li> <li>Pre-Primed</li> <li>50 Year Limited Warranty</li> </ul>	<p><b>VINYL SIDING</b></p> <ul style="list-style-type: none"> <li>Maintenance Free</li> <li>.044 Thickness</li> <li>Match Your Home</li> <li>CDX Plywood Subsiding</li> </ul>	<p><b>PINE SIDING</b></p> <ul style="list-style-type: none"> <li>1 x 8 Premium Grade Pine Siding</li> <li>Exclusive Rough Sawn Finish</li> <li>Aesthetically Pleasing</li> <li>Tongue &amp; Groove</li> </ul>	<p><b>BOARD &amp; BATTEN</b></p> <p>50 YEAR LIMITED WARRANTY</p> <ul style="list-style-type: none"> <li>Natural Wood Grain Texture</li> <li>100% Clear</li> <li>Pre-Primed</li> <li>50 Year Limited Warranty</li> </ul>	<p><b>DURATEMP SIDING</b></p> <p>50 YEAR LIMITED WARRANTY</p> <ul style="list-style-type: none"> <li>Natural Wood Grain Texture</li> <li>100% Clear</li> <li>Pre-Primed</li> <li>50 Year Limited Warranty</li> </ul>	<p><b>SMARTSIDE SIDING</b></p> <p>50 YEAR LIMITED WARRANTY</p> <ul style="list-style-type: none"> <li>Natural Wood Grain Texture</li> <li>100% Clear</li> <li>Pre-Primed</li> <li>50 Year Limited Warranty</li> </ul>
---	---	---	---	--	---



# Craftsman

Workshop • Potting Shed • Pool House

## OPTIONS

*ON THIS 10x14*

Driftwood Dimensional Shingles

2' x 3' Windows

202TW Doors

Flower Box / Shutter Set

Avocado / Almond / Bark



## BASE PRICE UNIT HOW IT'S BUILT



## CONFIGURATION IDEAS



## SIDING CHOICES View Pricing Guide For Current Pricing

<p><b>SMARTSIDE LAP SIDING</b></p> <p><b>50 YEAR LIMITED WARRANTY</b></p> <ul style="list-style-type: none"> <li>Natural Wood Grain Texture</li> <li>100% Clear</li> <li>Pre-Primed</li> <li>50 Year Limited Warranty</li> </ul> 	<p><b>VINYL SIDING</b></p> <ul style="list-style-type: none"> <li>Maintenance Free</li> <li>.044 Thickness</li> <li>Match Your Home</li> <li>CDX Plywood Subiding</li> </ul> 	<p><b>PINE SIDING</b></p> <ul style="list-style-type: none"> <li>1 x 8 Premium Grade Pine Siding</li> <li>Exclusive Rough Sawn Finish</li> <li>Aesthetically Pleasing</li> <li>Tongue &amp; Groove</li> </ul> 	<p><b>BOARD &amp; BATTEN</b></p> <p><b>50 YEAR LIMITED WARRANTY</b></p> <ul style="list-style-type: none"> <li>Natural Wood Grain Texture</li> <li>100% Clear</li> <li>Pre-Primed</li> <li>50 Year Limited Warranty</li> </ul> 	<p><b>DURATEMP SIDING</b></p> <p><b>50 YEAR LIMITED WARRANTY</b></p> <ul style="list-style-type: none"> <li>Natural Wood Grain Texture</li> <li>100% Clear</li> <li>Pre-Primed</li> <li>50 Year Limited Warranty</li> </ul> 	<p><b>SMARTSIDE SIDING</b></p> <p><b>50 YEAR LIMITED WARRANTY</b></p> <ul style="list-style-type: none"> <li>Natural Wood Grain Texture</li> <li>100% Clear</li> <li>Pre-Primed</li> <li>50 Year Limited Warranty</li> </ul> 
--	--	---	--	---	--



# Estate

Storage • Workshop • Studio

## OPTIONS

*ON THIS 12x16*

Driftwood Dimensional Shingles  
2' x 3' Windows  
101SW + VERTICAL TRIM BOARD Doors  
Flower Box / Shutter Set  
Shale / Navajo White / Natural



## BASE PRICE UNIT HOW IT'S BUILT



## CONFIGURATION IDEAS



## SIDING CHOICES View Pricing Guide For Current Pricing

<p><b>SMARTSIDE LAP SIDING</b></p> <p>50 YEAR LIMITED WARRANTY</p> <ul style="list-style-type: none"> <li>Natural Wood Grain Texture</li> <li>100% Clear</li> <li>Pre-Primed</li> <li>50 Year Limited Warranty</li> </ul>	<p><b>VINYL SIDING</b></p> <ul style="list-style-type: none"> <li>Maintenance Free</li> <li>.044 Thickness</li> <li>Match Your Home</li> <li>CDX Plywood Subiding</li> </ul>	<p><b>PINE SIDING</b></p> <ul style="list-style-type: none"> <li>1 x 8 Premium Grade Pine Siding</li> <li>Exclusive Rough Sawn Finish</li> <li>Aesthetically Pleasing</li> <li>Tongue &amp; Groove</li> </ul>	<p><b>BOARD &amp; BATTEN</b></p> <p>50 YEAR LIMITED WARRANTY</p> <ul style="list-style-type: none"> <li>Natural Wood Grain Texture</li> <li>100% Clear</li> <li>Pre-Primed</li> <li>50 Year Limited Warranty</li> </ul>	<p><b>DURATEMP SIDING</b></p> <p>50 YEAR LIMITED WARRANTY</p> <ul style="list-style-type: none"> <li>Natural Wood Grain Texture</li> <li>100% Clear</li> <li>Pre-Primed</li> <li>50 Year Limited Warranty</li> </ul>	<p><b>SMARTSIDE SIDING</b></p> <p>50 YEAR LIMITED WARRANTY</p> <ul style="list-style-type: none"> <li>Natural Wood Grain Texture</li> <li>100% Clear</li> <li>Pre-Primed</li> <li>50 Year Limited Warranty</li> </ul>
---	--	---	---	--	---



# Woodshed

Workshop • Cabin • Pool House

## OPTIONS

*ON THIS 10x16*  
Galvalume Metal Roof  
2' x 3' Windows  
Shutter Set  
204 SD Front Door  
Ebony / Black / Chestnut Brown  
Cupola



## BASE PRICE UNIT HOW IT'S BUILT



## CONFIGURATION IDEAS



## SIDING CHOICES View Pricing Guide For Current Pricing

<p><b>SMARTSIDE LAP SIDING</b></p> <p>50 YEAR LIMITED WARRANTY</p> <ul style="list-style-type: none"> <li>Natural Wood Grain Texture</li> <li>100% Clear</li> <li>Pre-Primed</li> <li>50 Year Limited Warranty</li> </ul> <p><b>LP</b></p>	<p><b>VINYL SIDING</b></p> <ul style="list-style-type: none"> <li>Maintenance Free</li> <li>.044 Thickness</li> <li>Match Your Home</li> <li>CDX Plywood Subsidng</li> </ul> <p><b>ProVia</b> HEARTTECH</p>	<p><b>PINE SIDING</b></p> <ul style="list-style-type: none"> <li>1 x 8 Premium Grade Pine Siding</li> <li>Exclusive Rough Sawn Finish</li> <li>Aesthetically Pleasing</li> <li>Tongue &amp; Groove</li> </ul> <p></p>	<p><b>BOARD &amp; BATTEN</b></p> <p>50 YEAR LIMITED WARRANTY</p> <ul style="list-style-type: none"> <li>Natural Wood Grain Texture</li> <li>100% Clear</li> <li>Pre-Primed</li> <li>50 Year Limited Warranty</li> </ul> <p><b>LP</b></p>	<p><b>DURATEMP SIDING</b></p> <p>50 YEAR LIMITED WARRANTY</p> <ul style="list-style-type: none"> <li>Natural Wood Grain Texture</li> <li>100% Clear</li> <li>Pre-Primed</li> <li>50 Year Limited Warranty</li> </ul> <p><b>Duratem</b></p>	<p><b>SMARTSIDE SIDING</b></p> <p>50 YEAR LIMITED WARRANTY</p> <ul style="list-style-type: none"> <li>Natural Wood Grain Texture</li> <li>100% Clear</li> <li>Pre-Primed</li> <li>50 Year Limited Warranty</li> </ul> <p><b>LP</b></p>
--	---	---	--	--	--



# Highland

Potting Shed • Cabin • Pool house

## OPTIONS

*ON THIS 10x16*

Onyx Black Dimensional Shingles

2' x 4' Windows

203LW Doors

Pioneer Brown / Natural





## BASE PRICE UNIT HOW IT'S BUILT



## CONFIGURATION IDEAS



## SIDING CHOICES View Pricing Guide For Current Pricing

<p><b>SMARTSIDE LAP SIDING</b>                  50 YEAR LIMITED WARRANTY                  • Natural Wood Grain Texture                  • 100% Clear                  • Pre-Primed                  • 50 Year Limited Warranty</p> 	<p><b>VINYL SIDING</b>                  • Maintenance Free                  • .044 Thickness                  • Match Your Home                  • CDX Plywood Subsiding</p> 	<p><b>PINE SIDING</b>                  • 1 x 8 Premium Grade Pine Siding                  • Exclusive Rough Sawn Finish                  • Aesthetically Pleasing                  • Tongue &amp; Groove</p> 	<p><b>BOARD &amp; BATTEN</b>                  50 YEAR LIMITED WARRANTY                  • Natural Wood Grain Texture                  • 100% Clear                  • Pre-Primed                  • 50 Year Limited Warranty</p> 	<p><b>DURATEMP SIDING</b>                  50 YEAR LIMITED WARRANTY                  • Natural Wood Grain Texture                  • 100% Clear                  • Pre-Primed                  • 50 Year Limited Warranty</p> 	<p><b>SMARTSIDE SIDING</b>                  50 YEAR LIMITED WARRANTY                  • Natural Wood Grain Texture                  • 100% Clear                  • Pre-Primed                  • 50 Year Limited Warranty</p> 
--	--	--	--	---	--



# Grand Junction

Storage • Gardening • Studio

## OPTIONS

*ON THIS 10x16*

Estate Gray Dimensional Shingles

2' x 3' Windows

103AW Cedar Double Door

Z Strap Shutters

Square Cut Trim

Chestnut Brown / Jamestown Red / Bronze



## BASE PRICE UNIT

HOW IT'S BUILT



## CONFIGURATION IDEAS



## SIDING CHOICES View Pricing Guide For Current Pricing

<p><b>SMARTSIDE LAP SIDING</b>                  50 YEAR LIMITED WARRANTY                  • Natural Wood Grain Texture                  • 100% Clear                  • Pre-Primed                  • 50 Year Limited Warranty</p> 	<p><b>VINYL SIDING</b>                  • Maintenance Free                  • .044 Thickness                  • Match Your Home                  • CDX Plywood Subsiding</p> 	<p><b>PINE SIDING</b>                  • 1 x 8 Premium Grade Pine Siding                  • Exclusive Rough Sawn Finish                  • Aesthetically Pleasing                  • Tongue &amp; Groove</p> 	<p><b>BOARD &amp; BATTEN</b>                  50 YEAR LIMITED WARRANTY                  • Natural Wood Grain Texture                  • 100% Clear                  • Pre-Primed                  • 50 Year Limited Warranty</p> 	<p><b>DURATEMP SIDING</b>                  50 YEAR LIMITED WARRANTY                  • Natural Wood Grain Texture                  • 100% Clear                  • Pre-Primed                  • 50 Year Limited Warranty</p> 	<p><b>SMARTSIDE SIDING</b>                  50 YEAR LIMITED WARRANTY                  • Natural Wood Grain Texture                  • 100% Clear                  • Pre-Primed                  • 50 Year Limited Warranty</p> 
--	--	--	--	---	--



# Studio

Studio • Poolhouse • Gardening

## OPTIONS

*ON THIS 10x18*  
2 x 2 Windows  
2 x 3 Windows  
Square Cut Trim  
202TW Doors

Chestnut Brown / Buckskin / Jamestown Red



## BASE PRICE UNIT HOW IT'S BUILT

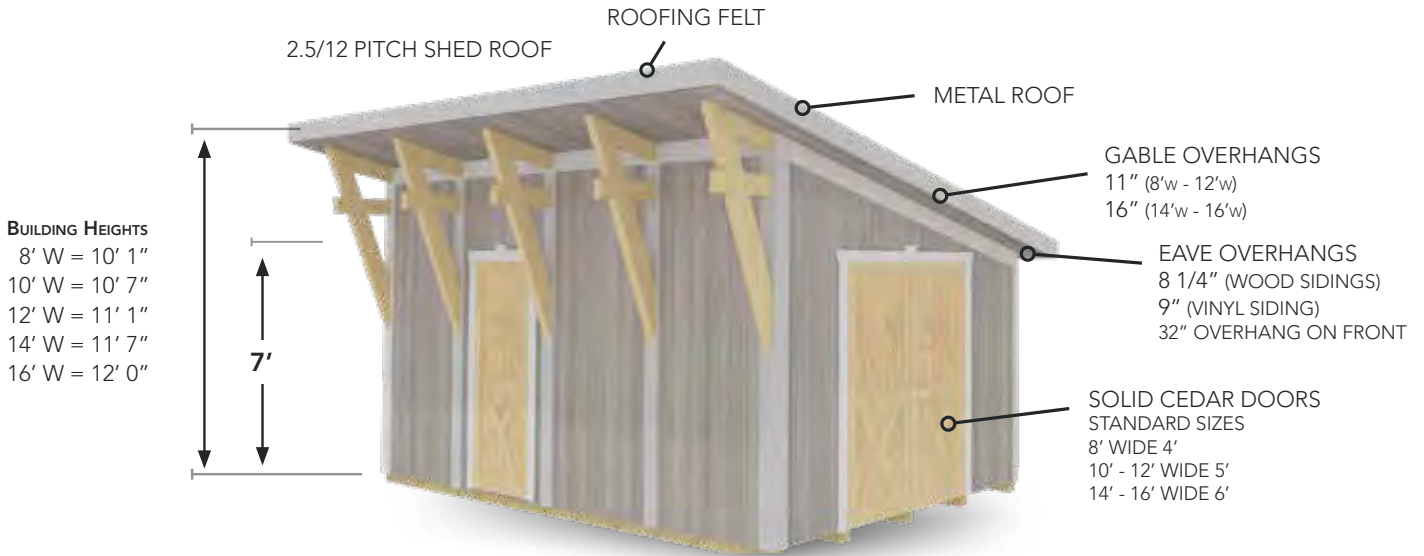

## CONFIGURATION IDEAS



## SIDING CHOICES View Pricing Guide For Current Pricing

<p><b>SMARTSIDE LAP SIDING</b>                  50 YEAR LIMITED WARRANTY  <ul style="list-style-type: none"> <li>Natural Wood Grain Texture</li> <li>100% Clear</li> <li>Pre-Primed</li> <li>50 Year Limited Warranty</li> </ul> </p>	<p><b>VINYL SIDING</b>  <ul style="list-style-type: none"> <li>Maintenance Free</li> <li>.044 Thickness</li> <li>Match Your Home</li> <li>CDX Plywood Subsidng</li> </ul> </p>	<p><b>PINE SIDING</b>  <ul style="list-style-type: none"> <li>1 x 8 Premium Grade Pine Siding</li> <li>Exclusive Rough Sawn Finish</li> <li>Aesthetically Pleasing</li> <li>Tongue &amp; Groove</li> </ul> </p>	<p><b>BOARD &amp; BATTEN</b>                  50 YEAR LIMITED WARRANTY  <ul style="list-style-type: none"> <li>Natural Wood Grain Texture</li> <li>100% Clear</li> <li>Pre-Primed</li> <li>50 Year Limited Warranty</li> </ul> </p>	<p><b>DURATEMP SIDING</b>                  50 YEAR LIMITED WARRANTY  <ul style="list-style-type: none"> <li>Natural Wood Grain Texture</li> <li>100% Clear</li> <li>Pre-Primed</li> <li>50 Year Limited Warranty</li> </ul> </p>	<p><b>SMARTSIDE SIDING</b>                  50 YEAR LIMITED WARRANTY  <ul style="list-style-type: none"> <li>Natural Wood Grain Texture</li> <li>100% Clear</li> <li>Pre-Primed</li> <li>50 Year Limited Warranty</li> </ul> </p>
---	--	---	---	--	---



# Skür

Storage • Studio • Poolhouse

## OPTIONS

*ON THIS 10x14*  
Onyz Black Dimensional Shingles  
2' x 5' Windows  
Square Cut Trim  
204-SD Single Door (no grids)  
Black / Natural



## BASE PRICE UNIT HOW IT'S BUILT

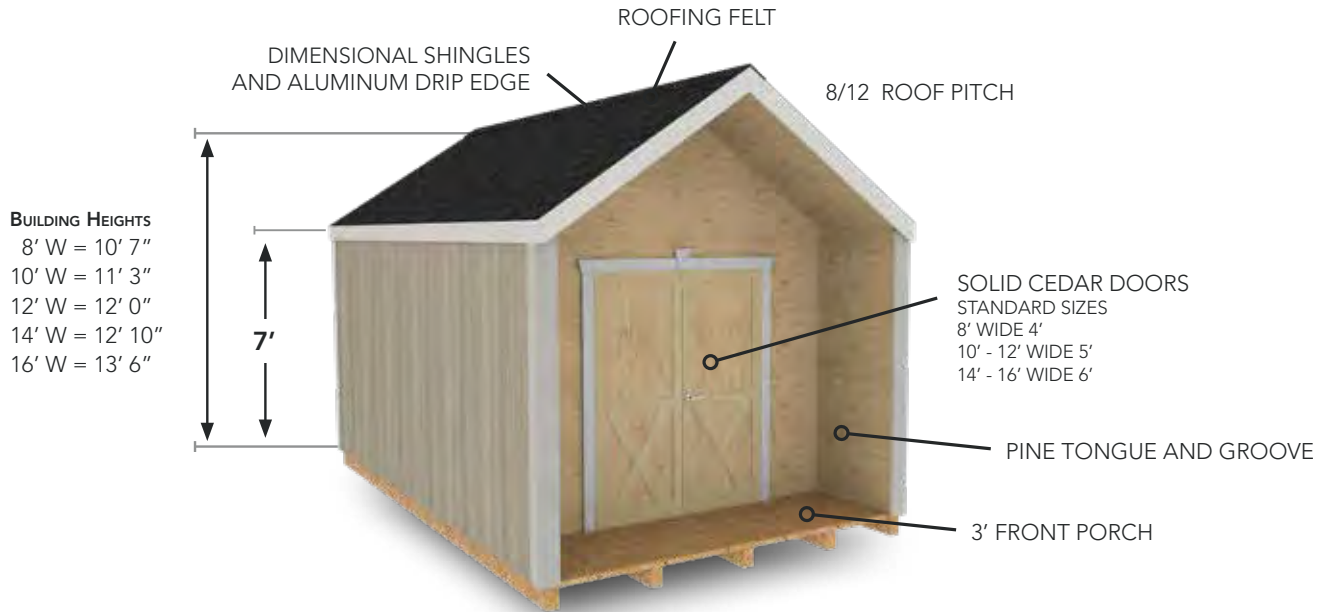

## CONFIGURATION IDEAS



## SIDING CHOICES View Pricing Guide For Current Pricing

<p><b>SMARTSIDE LAP SIDING</b></p> <p>50 YEAR LIMITED WARRANTY</p> <ul style="list-style-type: none"> <li>Natural Wood Grain Texture</li> <li>100% Clear</li> <li>Pre-Primed</li> <li>50 Year Limited Warranty</li> </ul>	<p><b>VINYL SIDING</b></p> <ul style="list-style-type: none"> <li>Maintenance Free</li> <li>.044 Thickness</li> <li>Match Your Home</li> <li>CDX Plywood Subsidng</li> </ul>	<p><b>PINE SIDING</b></p> <ul style="list-style-type: none"> <li>1 x 8 Premium Grade Pine Siding</li> <li>Exclusive Rough Sawn Finish</li> <li>Aesthetically Pleasing</li> <li>Tongue &amp; Groove</li> </ul>	<p><b>BOARD &amp; BATTEN</b></p> <p>50 YEAR LIMITED WARRANTY</p> <ul style="list-style-type: none"> <li>Natural Wood Grain Texture</li> <li>100% Clear</li> <li>Pre-Primed</li> <li>50 Year Limited Warranty</li> </ul>	<p><b>DURATEMP SIDING</b></p> <p>50 YEAR LIMITED WARRANTY</p> <ul style="list-style-type: none"> <li>Natural Wood Grain Texture</li> <li>100% Clear</li> <li>Pre-Primed</li> <li>50 Year Limited Warranty</li> </ul>	<p><b>SMARTSIDE SIDING</b></p> <p>50 YEAR LIMITED WARRANTY</p> <ul style="list-style-type: none"> <li>Natural Wood Grain Texture</li> <li>100% Clear</li> <li>Pre-Primed</li> <li>50 Year Limited Warranty</li> </ul>
---	--	---	---	--	---



# Easton

Studio • Office • Storage

## OPTIONS

*ON THIS 10x20*

Black Metal Roofing

204-FW 6' x 6'8" Doors (no grids)

2' x 5' Windows

Square Cut Trim

Bronze / Jamestown Red / Buckskin / Black





## BASE PRICE UNIT HOW IT'S BUILT



## CONFIGURATION IDEAS



## SIDING CHOICES View Pricing Guide For Current Pricing

<p><b>SMARTSIDE LAP SIDING</b> 50 YEAR LIMITED WARRANTY</p> <ul style="list-style-type: none"> <li>Natural Wood Grain Texture</li> <li>100% Clear</li> <li>Pre-Primed</li> <li>50 Year Limited Warranty</li> </ul>	<p><b>VINYL SIDING</b></p> <ul style="list-style-type: none"> <li>Maintenance Free</li> <li>.044 Thickness</li> <li>Match Your Home</li> <li>CDX Plywood Subsidng</li> </ul>	<p><b>PINE SIDING</b></p> <ul style="list-style-type: none"> <li>1 x 8 Premium Grade Pine Siding</li> <li>Exclusive Rough Sawn Finish</li> <li>Aesthetically Pleasing</li> <li>Tongue &amp; Groove</li> </ul>	<p><b>BOARD &amp; BATTEN</b> 50 YEAR LIMITED WARRANTY</p> <ul style="list-style-type: none"> <li>Natural Wood Grain Texture</li> <li>100% Clear</li> <li>Pre-Primed</li> <li>50 Year Limited Warranty</li> </ul>	<p><b>DURATEMP SIDING</b> 50 YEAR LIMITED WARRANTY</p> <ul style="list-style-type: none"> <li>Natural Wood Grain Texture</li> <li>100% Clear</li> <li>Pre-Primed</li> <li>50 Year Limited Warranty</li> </ul>	<p><b>SMARTSIDE SIDING</b> 50 YEAR LIMITED WARRANTY</p> <ul style="list-style-type: none"> <li>Natural Wood Grain Texture</li> <li>100% Clear</li> <li>Pre-Primed</li> <li>50 Year Limited Warranty</li> </ul>
--	--	---	--	---	--



# Shed Addition

Storage • Gardening

## OPTIONS

ON THIS 4x8  
Pictured: 12x18 Gable  
Jamestown Red



## BASE PRICE UNIT

### HOW IT'S BUILT

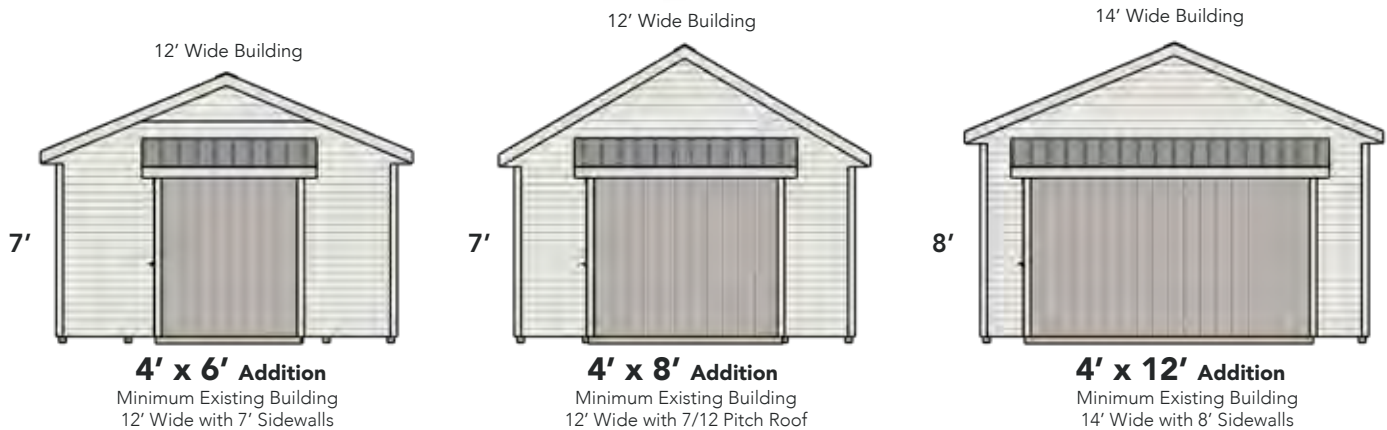

## SIDING CHOICES View Pricing Guide For Current Pricing

<p><b>SMARTSIDE LAP SIDING</b></p> <p>50 YEAR LIMITED WARRANTY</p> <ul style="list-style-type: none"> <li>Natural Wood Grain Texture</li> <li>100% Clear</li> <li>Pre-Primed</li> <li>50 Year Limited Warranty</li> </ul> <p><b>LP</b></p>	<p><b>VINYL SIDING</b></p> <ul style="list-style-type: none"> <li>Maintenance Free</li> <li>.044 Thickness</li> <li>Match Your Home</li> <li>CDX Plywood Subsiding</li> </ul> <p><b>ProVia</b> HEARTTECH</p>	<p><b>PINE SIDING</b></p> <ul style="list-style-type: none"> <li>1 x 8 Premium Grade Pine Siding</li> <li>Exclusive Rough Sawn Finish</li> <li>Aesthetically Pleasing</li> <li>Tongue &amp; Groove</li> </ul> <p><b>LP</b></p>	<p><b>BOARD &amp; BATTEN</b></p> <p>50 YEAR LIMITED WARRANTY</p> <ul style="list-style-type: none"> <li>Natural Wood Grain Texture</li> <li>100% Clear</li> <li>Pre-Primed</li> <li>50 Year Limited Warranty</li> </ul> <p><b>LP</b></p>	<p><b>DURATEMP SIDING</b></p> <p>50 YEAR LIMITED WARRANTY</p> <ul style="list-style-type: none"> <li>Natural Wood Grain Texture</li> <li>100% Clear</li> <li>Pre-Primed</li> <li>50 Year Limited Warranty</li> </ul> <p><b>DuraTemp</b></p>	<p><b>SMARTSIDE SIDING</b></p> <p>50 YEAR LIMITED WARRANTY</p> <ul style="list-style-type: none"> <li>Natural Wood Grain Texture</li> <li>100% Clear</li> <li>Pre-Primed</li> <li>50 Year Limited Warranty</li> </ul> <p><b>LP</b></p>
--	--	--	--	---	--

# TBASICS

STANDARD ON BACKYARD BASICS SHEDS

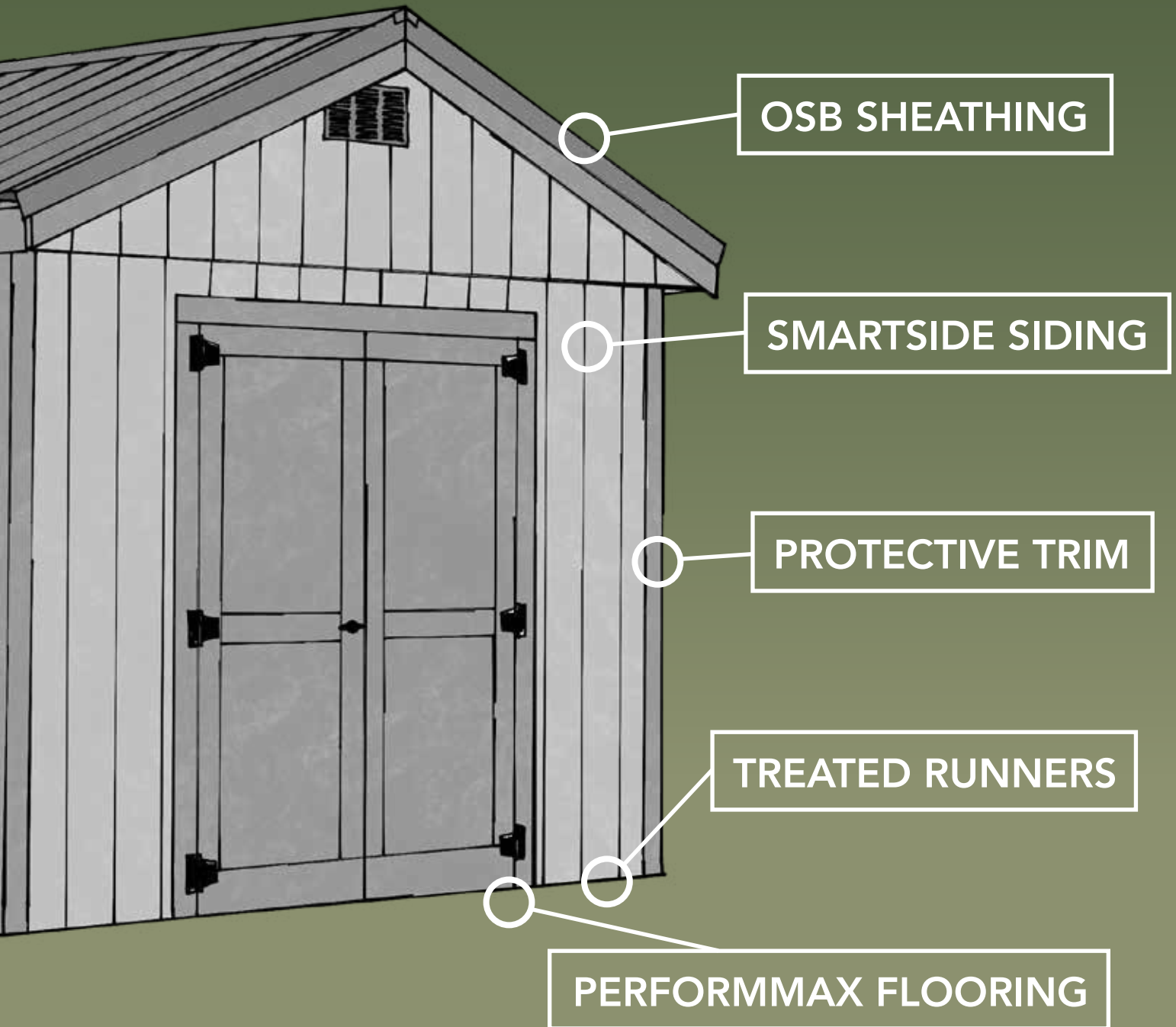

# BACKYARD BASICS

**Simple** is sometimes better. At Weaver Barns, we decided to take this principle and turn it into our BACKYARD BASICS. Using our core models, we created this new line that focuses on simplicity.

## 2 YEAR LIMITED WARRANTY

The first model, the JACKSON, features a classic gable-style roof. We created this design with a focus on functionality and simplicity. This model is a fantastic option for those in search of a storage space or workshop.

If you're looking for a reliable and spacious storage solution, the NEW HAVEN is an excellent option. With its classic roof design, this structure will be a standout addition to your property and will impress anyone who sees it.

Our third model, the ADDISON, stands out with its clean lines and modern shed roof. This design makes the perfect pool house, studio, or garden shed!

Our fourth and last design in this collection is the CAMDEN. This classic-style pavilion will make your backyard the envy of the neighborhood with its simple yet classic elegance.



SIMPLICITY BUILT RIGHT



# Jackson

## OPTIONS

ON THIS 10x14  
Bronze Metal Roofing  
#200 5' Double Doors  
Square Cut Trim  
Smoke / Bronze

### BASE PRICE UNIT

HOW IT'S BUILT

#### BUILDING HEIGHTS

- 8' W = 9' 8"
- 10' W = 10' 1"
- 12' W = 10' 6"
- 14' W = 11' 1"
- 16' W = 11' 6"





# Addison

## OPTIONS

ON THIS 10x12  
 Black Metal Roofing  
 #202-TW 5' Double Doors  
 Square Cut Trim  
 Pioneer / Ebony

### BASE PRICE UNIT HOW IT'S BUILT





# New Haven

## OPTIONS

ON THIS 10x14  
 Driftwood Shingles  
 #200 5' Double Doors  
 2x3 Windows  
 Square Cut Trim  
 Khaki / Navajo White / Bronze

## BASE PRICE UNIT

HOW IT'S BUILT

### BUILDING HEIGHTS

- 8' W = 10' 3"
- 10' W = 11'
- 12' W = 11' 9"
- 14' W = 12' 6"
- 16' W = 13' 3"







# Camden

## OPTIONS

ON THIS 12x14  
 Black Dimensional Shingles  
 Clay

### SIZES & POST LAYOUTS



#### SIZES IN THIS CONFIGURATION

10x10	12x14
10x12	12x16
10x16	14x14
12x12	14x16

### SPECIFICATIONS

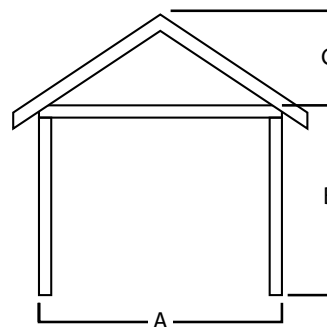

A	B	C
10'	7'4"	10' 2"
12'	7'4"	10' 7"
14'	7'4"	11' 0"



# BACKYARD LIVING





**OPTIONS**  
 ON THIS 12x12  
 • Smoke

# Laredo

Bold big timbers and elegant accents make the LAREDO pergola a perfect addition to your outdoor living space. For extra wow factor add it to a pavilion and create a duel zone outdoor entertainment area.

## HOW ITS MADE

Solid Cedar 8x8 Posts  
 Solid Cedar Beams  
 Solid Cedar Roof Slats

## SIZES & POST LAYOUTS



### SIZES IN THIS CONFIGURATION

- 10x10    12x16
- 10x12    14x14
- 10x16    14x16
- 12x12    16x16
- 12x14

## SPECIFICATIONS

width	A
10'	8'
12'	8'
14'	8'
16'	8'



#### OPTIONS

ON THIS 12x16

- Driftwood Stain
- Bronze Metal Roof

# Timber Ridge

Available In Solid Pine Or Cedar

Beautiful Timber Framing in a timeless design makes the TIMBER RIDGE Pavilion perfect in any setting. Large rustic solid wood beams and solid wood rafters defines the style and quality of this beautiful structure.

#### BASE PRICE MODEL STANDARD FEATURES

Rough Sawn Solid 8x8 Post's  
Rough Sawn Solid Carrier Beams  
Rough Sawn Solid Timber Frame  
style Gables  
Y-Support Bracing  
8/12 Pitch Roof  
Minimum 4x6 Rafter's 24" O.C.  
1x8 Tongue and Groove ceiling  
CDX Plywood Roof Sheathing  
Aluminum Drip Edge  
Dimensional Shingles

## BRACKET CHOICES



CURVED



STRAIGHT

## SIZES & POST LAYOUTS



SIZES IN THIS CONFIGURATION

10x10 12x14 16x16  
 10x12 12x16  
 10x16 14x14  
 12x12 14x16



SIZES IN THIS CONFIGURATION

12x20 14x28  
 12x24 16x20  
 14x20  
 14x24



SIZES IN THIS CONFIGURATION

14x32 20x20  
 16x24 20x24  
 16x28 20x28  
 16x32

## SPECIFICATIONS

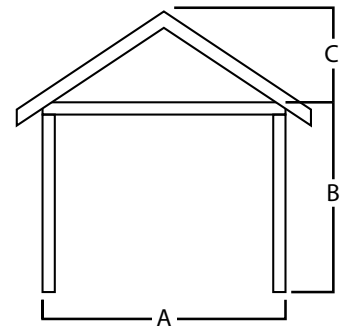

A	B	C
10'	8'	<b>11' 10"</b>
12'	8'	<b>12' 6"</b>
14'	8'	<b>13' 4"</b>
16'	8'	<b>14'</b>
20'	8'	<b>15' 7"</b>



**OPTIONS**

ON THIS 12x16

- Pecan
- Driftwood Dimensional Shingles



# Bradford

Available In Solid Pine Or Cedar

With bold rustic rough sawn beams and a classic hip roof, the BRADFORD is timeless in its design. A wonderful addition to a backyard or a pool side, you will love this beautiful structure.

**BASE PRICE MODEL**  
STANDARD FEATURES

- Rough Sawn Solid 8x8 Post's
- Rough Sawn Solid Carrier Beams
- Y-Support Bracing
- 7/12 Roof Pitch
- Minimum 4x6 Rafter's 24" O.C.
- 1x8 Tongue and Groove ceiling
- CDX Plywood Roof Sheathing
- Aluminum Drip Edge
- Dimensional Shingles

## BRACKET CHOICES



CURVED



STRAIGHT

## SIZES & POST LAYOUTS



4 POST

SIZES IN THIS CONFIGURATION

10x10 12x14 16x16  
 10x12 12x16  
 10x16 14x14  
 12x12 14x16



6 POST

SIZES IN THIS CONFIGURATION

12x20 14x32  
 12x24 16x20  
 14x20 16x24  
 14x24 16x28  
 14x28 16x32



8 POST

SIZES IN THIS CONFIGURATION

20x20  
 20x24  
 20x28  
 20x32

## SPECIFICATIONS

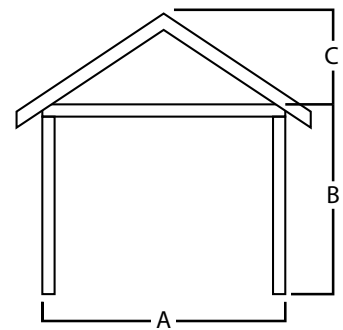

A	B	C
10'	8'	11' 6"
12'	8'	12' 1"
14'	8'	12' 10"
16'	8'	13' 5"
20'	8'	14' 9"



### OPTIONS

ON THIS 12x16

- Bronze Metal Roofing
- Natural / Chestnut Brown



# Lakewood

Available In Solid Pine Or Cedar

Mixing classic timber construction with a contemporary one sided roof makes the LAKEWOOD one of a kind. A standard open concept makes this pavilion perfect for you to enjoy with your friends and family.

### BASE PRICE MODEL STANDARD FEATURES

- Rough Sawn Solid 8x8 Post's
- Rough Sawn Solid Carrier Beams
- Y-Support Bracing
- 2/12 Roof Pitch
- Minimum 4x6 Rafter's 24" O.C.
- 1x8 Tongue and Groove ceiling
- CDX Plywood Roof Sheathing
- Steel Drip Edge
- Metal Roof
- 1' Overhang



## STRUCTURE OPTIONS

OPEN BACK  
STANDARD MODEL



CLOSED CEILING  
5% UPCHARGE



BACK & SIDE WALLS  
OPTIONAL WITH UPCHARGE



## SIZES & POST LAYOUTS



SIZES IN THIS CONFIGURATION

12x14  
12x16  
12x18  
14x16  
14x18



SIZES IN THIS CONFIGURATION

12x24  
12x28  
14x24  
14x26  
14x30

## SPECIFICATIONS

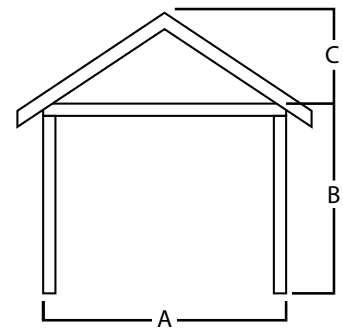

A	B	C
10'	7' 4"	10' 4"
12'	7' 4"	10' 9"
14'	7' 4"	11' 2"
16'	7' 4"	11' 7"



**OPTIONS**

ON THIS 12x16

- Solid Pine Stained Smoke / Natural
- Bronze Metal Roof



# Dublin

Available In Pine, Cedar & Vinyl

Everyone loves beautiful outdoor spaces. The DUBLIN with its clean flush ceiling, exposed post and beam detail and low maintenance construction option, makes it the perfect structure to make a statement in your backyard. Personalize it with beautiful bracket choices.

**BASE PRICE MODEL**  
STANDARD FEATURES (VINYL)

- Vinyl Wrapped 8x8 Post's
- Cellular PVC Wrapped Carrier Beams
- Cellular PVC Soffit & Fascia
- 7/12 Roof Pitch
- 2x6 Rafter's 24" O.C.
- 1x8 Tongue and Groove ceiling
- CDX Plywood Roof Sheathing
- Aluminum Drip Edge
- Dimensional Shingles

## VINYL BRACKET CHOICES



**CURVED**

\*ADDITIONAL COST  
(VINYL ONLY)



**ARCHED**

\*ADDITIONAL COST  
(VINYL ONLY)

## VINYL SIZES & POST LAYOUTS



SIZES IN THIS CONFIGURATION

10x10 12x14 16x16  
10x12 12x16 20x20  
10x16 14x14  
12x12 14x16



SIZES IN THIS CONFIGURATION

12x20 16x24  
12x24 16x28  
14x20 16x32  
14x24 20x24  
14x28 20x28  
14x32 20x32  
16x20

## SPECIFICATIONS

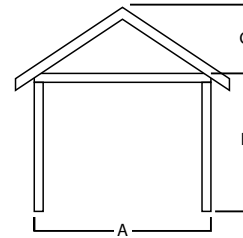

**VINYL**

**WOOD**

A	B	C
10'	9'	12' 3"
12'	9'	13' 1"
14'	9'	13' 8"
16'	9'	14' 3"
20'	9'	15' 5"

A	B	C
10'	8'	11' 8"
12'	8'	12' 5"
14'	8'	13'
16'	8'	13' 9"
20'	8'	14' 11"

## WOOD SIZES & POST LAYOUTS



SIZES IN THIS CONFIGURATION

10x10 12x14 16x16  
10x12 12x16  
10x16 14x14  
12x12 14x16



SIZES IN THIS CONFIGURATION

12x20 14x32  
12x24 16x20  
14x20 16x24  
14x24 16x28  
14x28 16x32



SIZES IN THIS CONFIGURATION

20x20  
20x24  
20x28  
20x32

# POST OPTIONS

Add accents to your wood post structures or change post colors on a vinyl structure

## WOOD POST OPTIONS



STANDARD  
WOOD  
POST



OPTIONAL  
SMOOTH  
PINE  
\*LIMITED  
COLORS



OPTIONAL  
BASE  
WOOD  
ACCENT

## VINYL POST OPTIONS



STANDARD  
WHITE  
VINYL  
SLEEVE



OPTIONAL  
CLAY  
VINYL  
SLEEVE

## WOOD BASE ACCENT



## 3' POST WRAP



# INSTALLATION METHODS

## DURA COLUMN POST SYSTEM

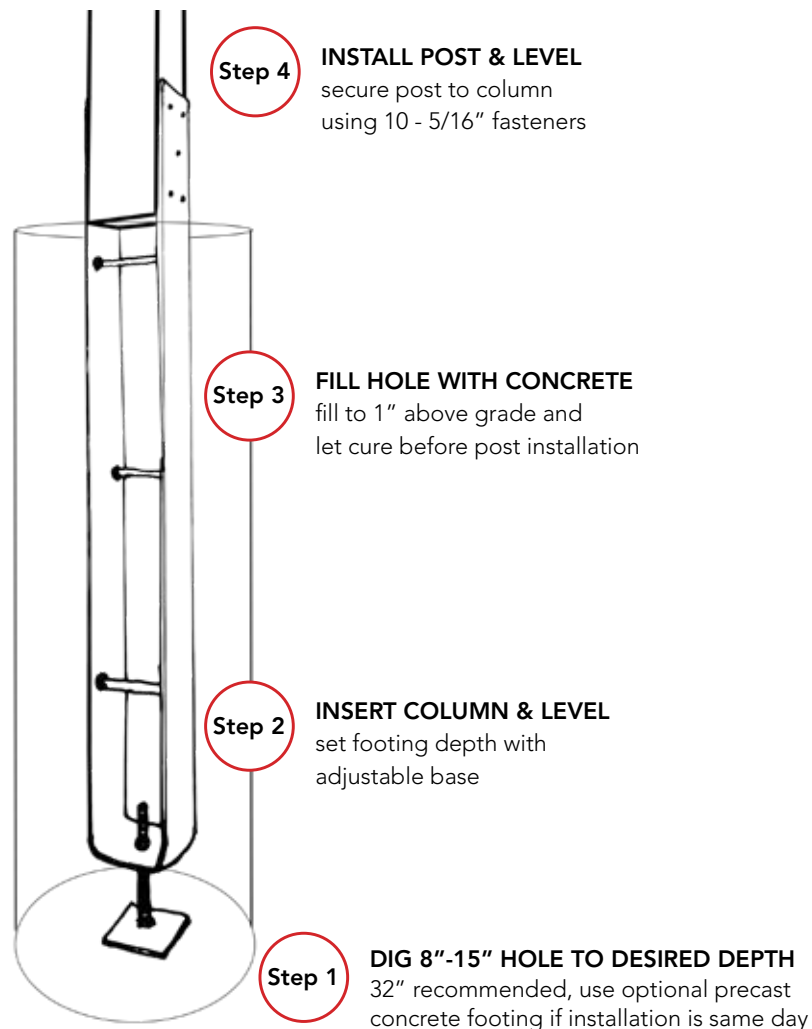

## METAL POST ANCHOR

### POST ABOVE GRADE

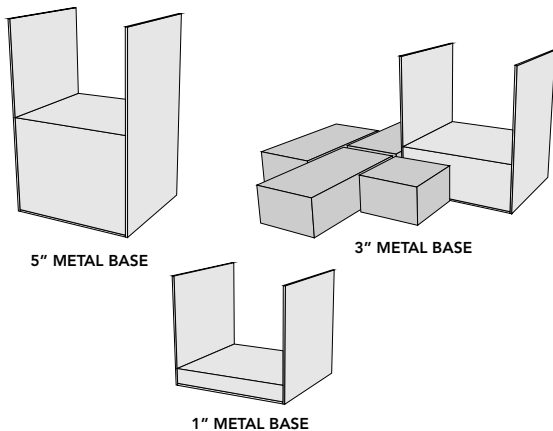

### OUR INCLUDED INSTALLATION METHOD

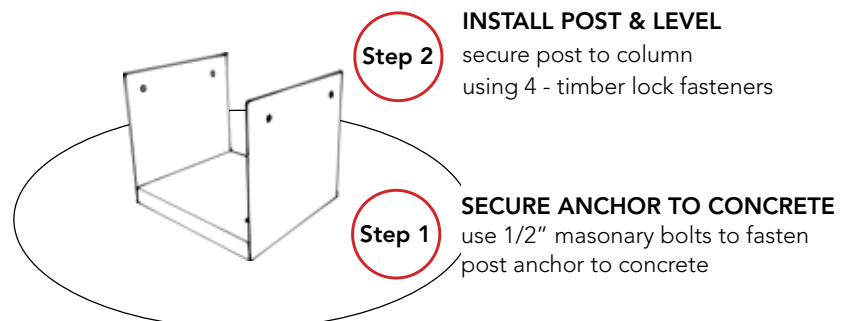

# GARAGES

Looking For A Garage? Discover The Process.

## Step 1 - Size?

### WHAT SIZE DO I NEED?

The first step in your design journey begins with size. What will you need to store, and what would you like to do with the space. Answering these questions early will save you time, money, and energy.

Layout Size Ideas

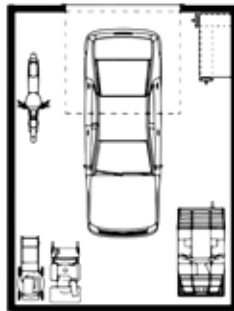

18x24 ONE CAR 432 Sq. Ft.

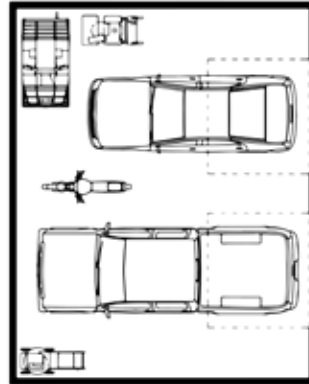

24x30 TWO CAR 720 Sq. Ft.

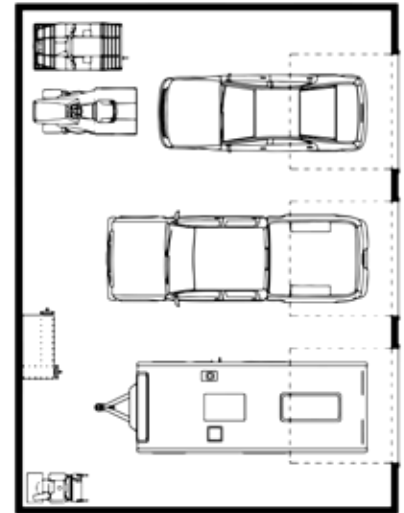

30x40 THREE CAR 1200 Sq. Ft.

## Step 2 - Design?



### NOT THE LOOK YOU WANT?

All of our models are base designs. We fully expect you to design the project to your ideas. Use our models as a basic concept, but don't limit yourself. We are a full custom builder. You dream it, we build it.

## Step 3 - Foundation Type?

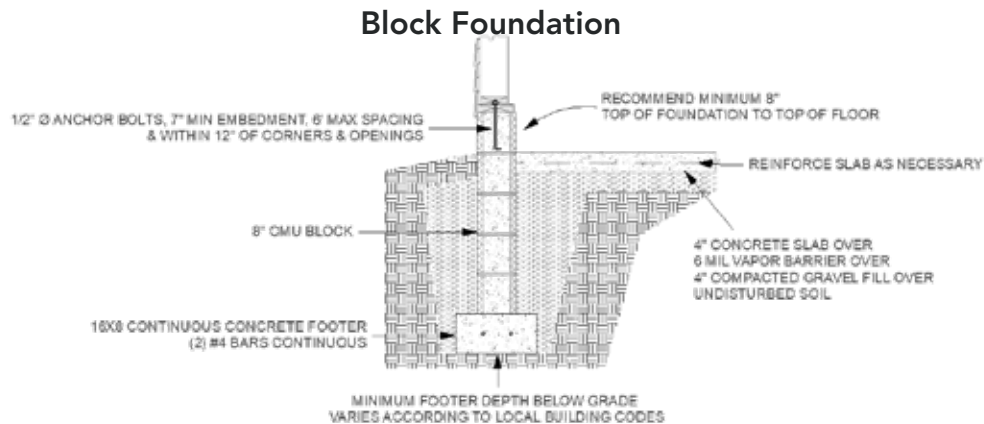

### Mono Pour Foundation

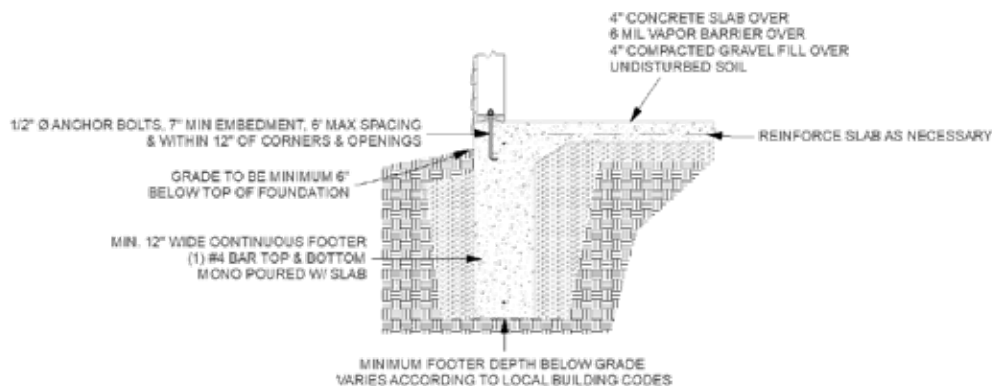

## Step 4 - Permits?

Weaver Barns builds in several different States. We ask the customer to be involved and pull the permits on projects that require that. We can provide the permit drawings and technical details required. Not all projects require permits, please inquire with local building, zoning, HOAs or any regulatory agency in your area.



## Step 5 - Construction?

Once you have these steps completed, you will be ready for construction to begin. Our team will help guide you throughout this process, and make it as smooth as possible. Remember, it is construction. Variables are to be expected. Things like weather can play a large role in meeting project milestones. We do our best to be as efficient as possible.





# Gable Garage

Garage • Storage • Workshop

## OPTIONS

*ON THIS 12x20*

2x4 Windows

Teak Dimensional Shingles

Chestnut Brown / Buckskin

Windows in Garage Door



# Gable Garage



## BASE PRICE UNIT

HOW IT'S BUILT

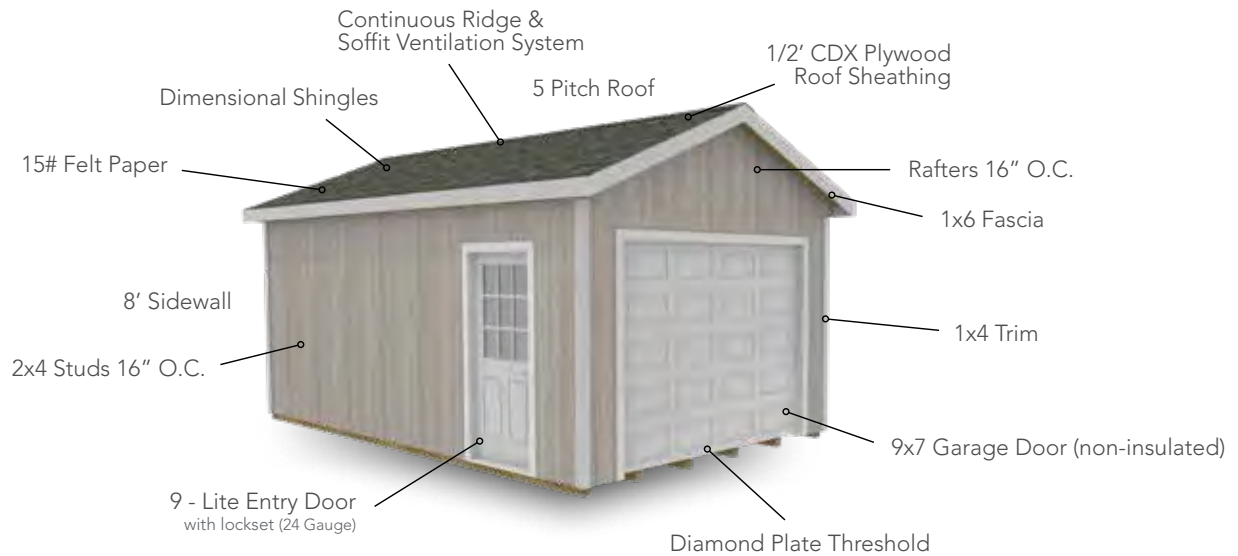

### INFORMATION

\*free delivery for 30 miles, delivery charges may apply beyond 30 Miles

#### BUILDING HEIGHTS

12' Wide = 11' 7" High  
 14' Wide = 12' 0" High  
 16' Wide = 12' 5" High



## SIDING CHOICES View Pricing Guide For Current Pricing

<p><b>SMARTSIDE LAP SIDING</b></p> <p>50 YEAR LIMITED WARRANTY</p> <ul style="list-style-type: none"> <li>Natural Wood Grain Texture</li> <li>100% Clear</li> <li>Pre-Primed</li> <li>50 Year Limited Warranty</li> </ul> <p><b>LP</b></p>	<p><b>VINYL SIDING</b></p> <ul style="list-style-type: none"> <li>Maintenance Free</li> <li>.044 Thickness</li> <li>Match Your Home</li> <li>CDX Plywood Subsidizing</li> </ul> <p><b>ProVia HEARTTECH</b></p>	<p><b>PINE SIDING</b></p> <ul style="list-style-type: none"> <li>1 x 8 Premium Grade Pine Siding</li> <li>Exclusive Rough Sawn Finish</li> <li>Aesthetically Pleasing</li> <li>Tongue &amp; Groove</li> </ul> <p></p>	<p><b>BOARD &amp; BATTEN</b></p> <p>50 YEAR LIMITED WARRANTY</p> <ul style="list-style-type: none"> <li>Natural Wood Grain Texture</li> <li>100% Clear</li> <li>Pre-Primed</li> <li>50 Year Limited Warranty</li> </ul> <p><b>LP</b></p>	<p><b>DURATEMP SIDING</b></p> <p>50 YEAR LIMITED WARRANTY</p> <ul style="list-style-type: none"> <li>Natural Wood Grain Texture</li> <li>100% Clear</li> <li>Pre-Primed</li> <li>50 Year Limited Warranty</li> </ul> <p><b>DuraTemp</b></p>	<p><b>SMARTSIDE SIDING</b></p> <p>50 YEAR LIMITED WARRANTY</p> <ul style="list-style-type: none"> <li>Natural Wood Grain Texture</li> <li>100% Clear</li> <li>Pre-Primed</li> <li>50 Year Limited Warranty</li> </ul> <p><b>LP</b></p>
--	--	---	--	---	--

# Workshop

## OPTIONS ON THIS 18x24

- 12 x 7 Carriage House Door
- 2' x 4' Aluminum Windows
- Driftwood Shingles
- Natural Cedar Shakes
- Windows In Garage Door
- Painted Clay / White
- Timber Frame Bracket



## WORKSHOP ESTIMATE MATRIX



### Basic

- Size: 16 x 20
- Painted Smartside Siding
- 1 - 12 x 7 Insulated Garage Doors
- 1 - 6 Panel Steel Door
- 30 Year Shingle Roof
- Timber Frame Bracket
- 8' Walls

Estimated Price **\$20,900**  
+ Foundation & Concrete \$5,200 - \$12,000



### Deluxe

- Size: 18 x 24
- Painted Smartside Siding
- 1 - 12 x 7 Insulated Garage Doors
- 1 - 6 Panel Steel Door
- 30 Year Shingle Roof
- Timber Frame Bracket
- 8' Walls
- 2x4 Aluminum Window
- Cedar Shakes

Estimated Price **\$25,600**  
+ Foundation & Concrete \$7,000 - \$19,000



### Ultimate

- Size: 20 x 32
- Painted LP Lap Siding
- 1 - 12 x 7 Carriage Garage Doors
- 1 - 9 Light Steel Door
- Metal Roof
- Cupola
- Timber Frame Bracket
- 2x4 + Transom Aluminum Windows
- Door Awning + Arbor

Estimated Price **\$41,600**  
+ Foundation & Concrete \$11,000 - \$15,000



## BASE PRICE UNIT

HOW IT'S BUILT

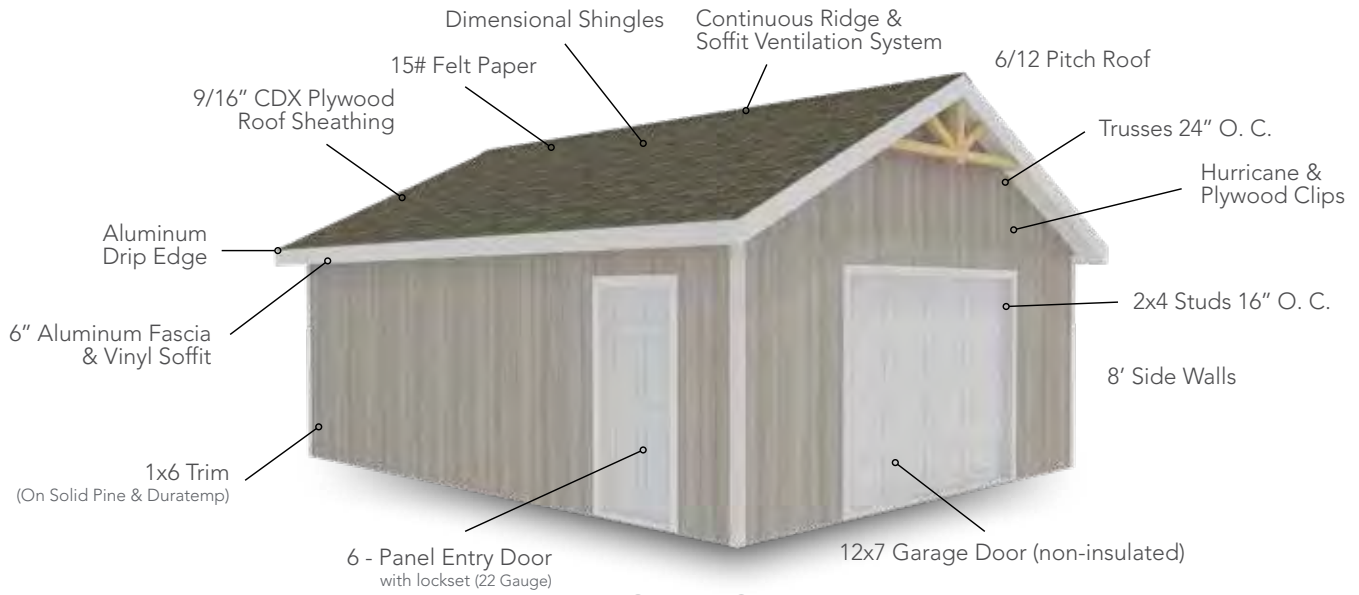

### INFORMATION

\*free delivery for 30 miles, delivery charges may apply beyond 30 Miles

The Workshop is real property No additional sales tax charged

Floor is not included

#### BUILDING HEIGHTS

16' Wide = 12' 6" High  
 18' Wide = 13' 0" High  
 20' Wide = 13' 6" High



## SIDING CHOICES [View Pricing Guide For Current Pricing](#)

<p><b>SMARTSIDE LAP SIDING</b></p> <p>50 YEAR LIMITED WARRANTY</p> <ul style="list-style-type: none"> <li>Natural Wood Grain Texture</li> <li>100% Clear</li> <li>Pre-Primed</li> <li>50 Year Limited Warranty</li> </ul>	<p><b>VINYL SIDING</b></p> <ul style="list-style-type: none"> <li>Maintenance Free</li> <li>.044 Thickness</li> <li>Match Your Home</li> <li>CDX Plywood Subsidizing</li> </ul>	<p><b>PINE SIDING</b></p> <ul style="list-style-type: none"> <li>1 x 8 Premium Grade Pine Siding</li> <li>Exclusive Rough Sawn Finish</li> <li>Aesthetically Pleasing</li> <li>Tongue &amp; Groove</li> </ul>	<p><b>BOARD &amp; BATTEN</b></p> <p>50 YEAR LIMITED WARRANTY</p> <ul style="list-style-type: none"> <li>Natural Wood Grain Texture</li> <li>100% Clear</li> <li>Pre-Primed</li> <li>50 Year Limited Warranty</li> </ul>	<p><b>DURATEMP SIDING</b></p> <p>50 YEAR LIMITED WARRANTY</p> <ul style="list-style-type: none"> <li>Natural Wood Grain Texture</li> <li>100% Clear</li> <li>Pre-Primed</li> <li>50 Year Limited Warranty</li> </ul>	<p><b>SMARTSIDE SIDING</b></p> <p>50 YEAR LIMITED WARRANTY</p> <ul style="list-style-type: none"> <li>Natural Wood Grain Texture</li> <li>100% Clear</li> <li>Pre-Primed</li> <li>50 Year Limited Warranty</li> </ul>
---	---	---	---	--	---

# The Classic

## OPTIONS ON THIS 24x32

- Estate Gray Dimensional Shingles
- Custom Cupola
- 16 x 7 Carriage House Door
- 3' x 4' Vinyl Windows
- Vinyl Shutters
- Gutters and Downspouts
- Windows In Garage Door
- Pewter / White



## CLASSIC ESTIMATE MATRIX



### Two Car Basic

- Size: 24 x 24
- Painted Smartside Siding
- 2 - 9 x 7 Uninsulated Garage Doors
- 1 - 9 Light Steel Door
- Dimensional Shingle Roof
- 8' Walls

Estimated Price **\$26,900**  
+ Foundation & Concrete \$9,000 - \$14,500



### Two Car Deluxe

- Size: 24 x 24
- Vinyl Siding
- 2 - 9 x 7 Insulated Carriage Doors
- 2 - 3 x 4 Vinyl Window
- 1 - 9 Light Steel Door
- Dimensional Shingle Roof
- 8' Walls
- 7/12 Pitch Roof Upgrade

Estimated Price **\$34,100**  
+ Foundation & Concrete \$9,000 - \$14,000



### Three Car Deluxe

- Size: 24 x 36
- Vinyl Siding
- 3- 9 x 7 Insulated Carriage Doors
- 4 - 3 x 4 Vinyl Window
- 1 - 9 Light Steel Door
- Dimensional Shingle Roof
- 9' Walls
- 8/12 Pitch Roof Upgrade

Estimated Price **\$49,900**  
+ Foundation & Concrete \$12,000 - \$19,000

# The Classic

Garages



## BASE PRICE UNIT

HOW IT'S BUILT

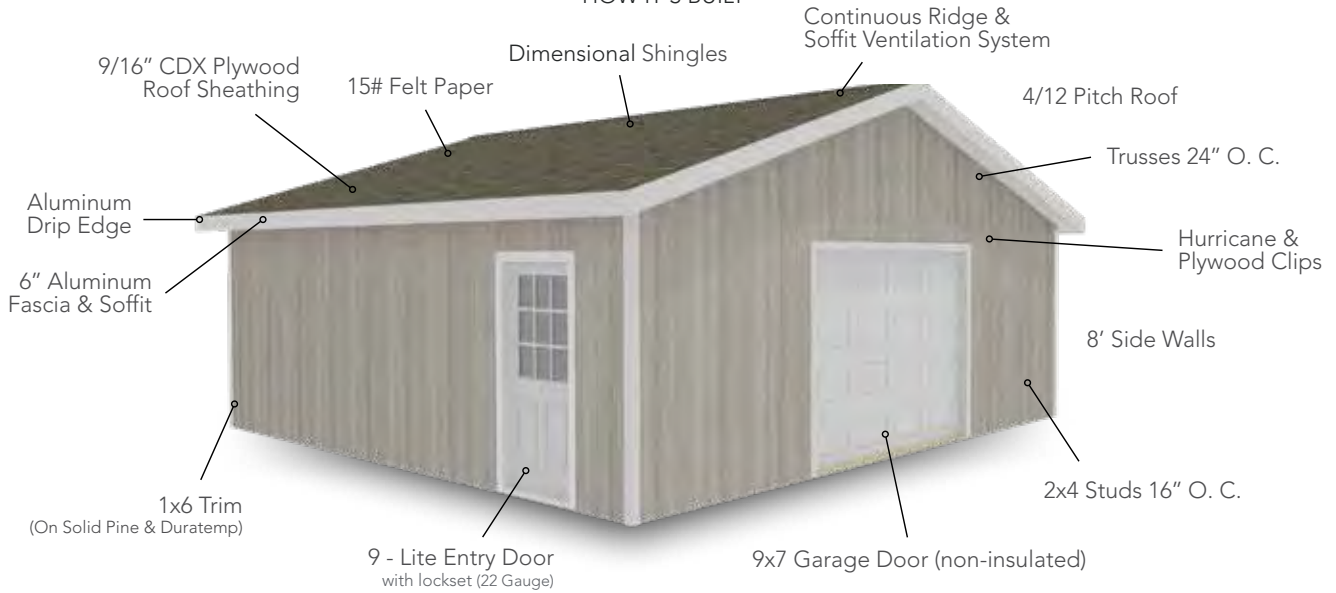

### INFORMATION

\*free delivery for 30 miles, delivery charges may apply beyond 30 Miles

The Classic is real property No additional sales tax charged

Floor is not included

### BUILDING HEIGHTS

24' Wide = 12' 5" High  
30' Wide = 13' 5" High



## SIDING CHOICES [View Pricing Guide For Current Pricing](#)

### SMARTSIDE LAP SIDING

- 50 YEAR LIMITED WARRANTY**
- Natural Wood Grain Texture
  - 100% Clear
  - Pre-Primed
  - 50 Year Limited Warranty



### VINYL SIDING

- Maintenance Free
- .044 Thickness
- Match Your Home
- CDX Plywood Subsidizing



### PINE SIDING

- 1 x 8 Premium Grade Pine Siding
- Exclusive Rough Sawn Finish
- Aesthetically Pleasing
- Tongue & Groove



### BOARD & BATTEN

- 50 YEAR LIMITED WARRANTY**
- Natural Wood Grain Texture
  - 100% Clear
  - Pre-Primed
  - 50 Year Limited Warranty



### DURATEMP SIDING

- 50 YEAR LIMITED WARRANTY**
- Natural Wood Grain Texture
  - 100% Clear
  - Pre-Primed
  - 50 Year Limited Warranty



### SMARTSIDE SIDING

- 50 YEAR LIMITED WARRANTY**
- Natural Wood Grain Texture
  - 100% Clear
  - Pre-Primed
  - 50 Year Limited Warranty



# Heritage

## OPTIONS ON THIS 24x36

- Custom Cupola
- 9 x 9 Carriage House OHD
- 10' Walls
- Custom Window Package
- Painted Steel Entry Door
- Metal Roof Charcoal
- Full Length Awning
- Windows In Garage Door
- Jamestown Red / Clay



## HERITAGE ESTIMATE MATRIX



### Two Car Basic

- Size: 24 x 24
- Painted Smartside Siding
- 2 - 9 x 7 Insulated Garage Doors
- 1 - 9 Light Steel Door
- Dimensional Shingle Roof
- 9' Walls
- Full Attic with Attic Pull Down Steps

Estimated Price **\$38,900**  
 + Foundation & Concrete \$9,000 - \$14,000



### Two Car Deluxe

- Size: 24 x 28
- Painted Smartside Siding
- 2 - 9 x 7 Insulated Carriage Doors
- 3 - 2 x 4 with Transom Above
- 3 - 2 x 3 Aluminum Windows
- 1 - 9 Light Steel Door
- Metal Roof
- 9' Walls
- Full Attic With Steps And Landing
- Stone Accents & Open Rafter Awnings

Estimated Price **\$53,900**  
 + Foundation & Concrete \$12,000 - \$16,000



### Three Car Deluxe

- Size: 24 x 36
- Painted Duratemp Siding
- 2 - 9 x 7 Insulated Carriage Doors
- 4 - 2 x 4 with Transom Above
- 3 - 2 x 3 Aluminum Windows
- 1 - 9 Light Steel Door
- Metal Roof - with Cupola & Weathervane
- 9' Walls
- Full Attic With Steps And Landing
- Stone Accents & Open Rafter Awnings

Estimated Price **\$64,700**  
 + Foundation & Concrete \$13,000 - \$19,000



## BASE PRICE UNIT

HOW IT'S BUILT

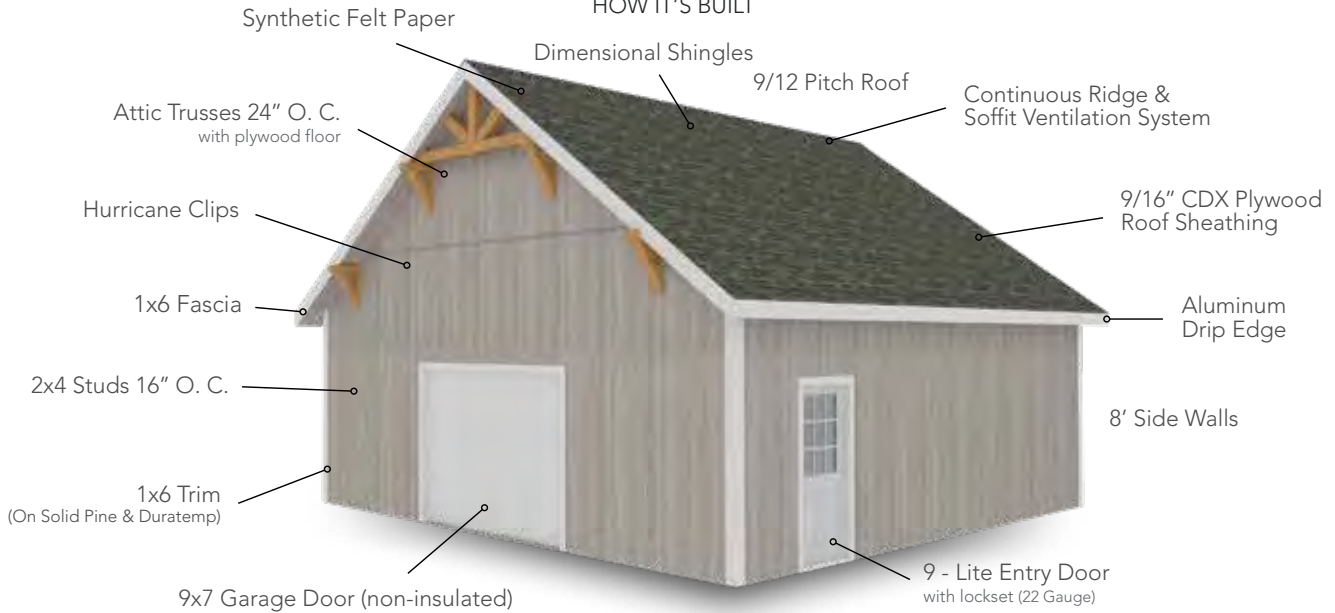

### INFORMATION

\*free delivery for 30 miles, delivery charges may apply beyond 30 Miles

The Heritage is real property No additional sales tax charged

Floor is not included

### BUILDING HEIGHTS

20' Wide = 16' 2" High  
 24' Wide = 17' 8" High  
 30' Wide = 19' 11" High



## SIDING CHOICES [View Pricing Guide For Current Pricing](#)

### SMARTSIDE LAP SIDING

- 50 YEAR LIMITED WARRANTY
- Natural Wood Grain Texture
- 100% Clear
- Pre-Primed
- 50 Year Limited Warranty



### VINYL SIDING

- Maintenance Free
- .044 Thickness
- Match Your Home
- CDX Plywood Subsidizing



### PINE SIDING

- 1 x 8 Premium Grade Pine Siding
- Exclusive Rough Sawn Finish
- Aesthetically Pleasing
- Tongue & Groove



### BOARD & BATTEN

- 50 YEAR LIMITED WARRANTY
- Natural Wood Grain Texture
- 100% Clear
- Pre-Primed
- 50 Year Limited Warranty



### DURATEMP SIDING

- 50 YEAR LIMITED WARRANTY
- Natural Wood Grain Texture
- 100% Clear
- Pre-Primed
- 50 Year Limited Warranty



### SMARTSIDE SIDING

- 50 YEAR LIMITED WARRANTY
- Natural Wood Grain Texture
- 100% Clear
- Pre-Primed
- 50 Year Limited Warranty



# Rockport

## OPTIONS ON THIS 32x24

- Vinyl Windows
- 3' x 4' Vinyl Windows
- Stone Work
- Cupola
- Onyx Black Dimensional Shingles
- Board & Batten Vinyl Siding
- 16' x 7' Carriage House Door
- Windows In Garage Door 2' x 3'



## ROCKPORT ESTIMATE MATRIX



### Two Car Basic

- Size: 24 x 20
- Painted Smartside Siding
- 1 - 16 x 7 Insulated Garage Doors
- 1 - 9 Light Steel Door
- Loft with Attic Ladder
- 30 Year Shingle Roof
- 8' Walls

Estimated Price **\$36,300**  
 + Foundation & Concrete \$9,000 - \$13,000



### Two Car Deluxe

- Size: 32 x 24
- Vinyl Siding
- 1 - 16 x 7 Insulated Carriage Doors
- 4 - 2 x 3 Vinyl Window
- 1 - 9 Light Steel Door
- 30 Year Shingle Roof
- Loft with Attic Ladder
- 8' Walls
- 42" Stone Wainscot (2 Sides)

Estimated Price **\$56,100**  
 + Foundation & Concrete \$12,000 - \$16,000



### Three Car Deluxe

- Size: 40 x 30
- Vinyl Siding
- 1 - 16 x 8
- 1 - 10 x 8
- 4 - 2 x 4 Vinyl SH
- Dimensional Shingles
- 3/4 Glass Entry
- 32" Stone Wainscot (2 Sides)
- 10' Walls
- Attic Truss w/ Loft & Ladder
- Cupola

Estimated Price **\$87,500**  
 + Foundation & Concrete \$15,000 - \$21,000





## BASE PRICE UNIT

HOW IT'S BUILT

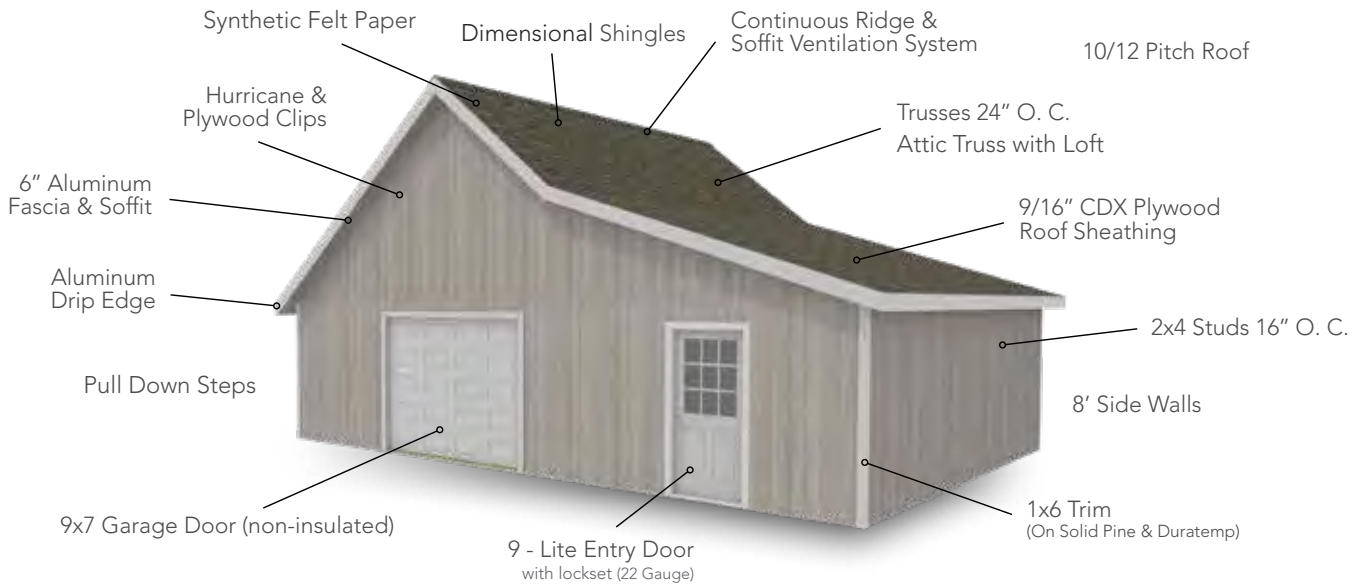

### INFORMATION

\*free delivery for 30 miles, delivery charges may apply beyond 30 Miles

The Rockport is real property No additional sales tax charged

Floor is not included

### BUILDING HEIGHTS

20' Wide = 17' 1" High  
24' Wide = 18' 9" High  
30' Wide = 21' 3" High



## SIDING CHOICES View Pricing Guide For Current Pricing

### SMARTSIDE LAP SIDING

- 50 YEAR LIMITED WARRANTY
- Natural Wood Grain Texture
- 100% Clear
- Pre-Primed
- 50 Year Limited Warranty



### VINYL SIDING

- Maintenance Free
- .044 Thickness
- Match Your Home
- CDX Plywood Subsiding



### PINE SIDING

- 1 x 8 Premium Grade Pine Siding
- Exclusive Rough Sawn Finish
- Aesthetically Pleasing
- Tongue & Groove



### BOARD & BATTEN

- 50 YEAR LIMITED WARRANTY
- Natural Wood Grain Texture
- 100% Clear
- Pre-Primed
- 50 Year Limited Warranty



### DURATEMP SIDING

- 50 YEAR LIMITED WARRANTY
- Natural Wood Grain Texture
- 100% Clear
- Pre-Primed
- 50 Year Limited Warranty



### SMARTSIDE SIDING

- 50 YEAR LIMITED WARRANTY
- Natural Wood Grain Texture
- 100% Clear
- Pre-Primed
- 50 Year Limited Warranty



# Willow Creek

## OPTIONS ON THIS 24x36

- 9x7 Long Panel Carriage House Doors
- Timbers Stained Pioneer
- Textured Legacy Metal Roof
- Painted Steel Entry Door
- White Vinyl Board & Batten Siding
- Door Awning
- 8' Lean-to with RS Pine Timbers
- Black Vinyl Window Package
- 40" Traditional Cupola with Black Roof
- Copper Eagle Weathervane



## WILLOW CREEK ESTIMATE MATRIX



### Two Car Basic

- Size: 20 x 24
- Painted Smartside Siding
- 1 - 16 x 7 Insulated Garage Doors
- 1 - 9 Light Steel Door
- Shingle Roof
- 10' Walls
- Half Loft & Steps with Landing

Estimated Price **\$42,300**  
+ Foundation & Concrete \$9,000 - \$13,000



### Two Car Deluxe

- Size: 24 x 32
- Painted Smartside Siding
- 2 - 9 x 7 Insulated Carriage Doors
- 4 - 2 x 4 + 3 - 2 x 3 Aluminum Windows
- 1 - 9 Light Steel Door
- Dimensional Shingle Roof
- 10' Walls
- Half Loft & Steps with Landing
- Awning

Estimated Price **\$60,900**  
+ Foundation & Concrete \$12,000 - \$16,000



### Three Car Deluxe

- Size: 24 x 36
- Stained Pine Siding
- 2 - 9 x 7 Insulated Carriage Doors
- 5 - 2 x 4 + 3 - 2 x 3 Aluminum Windows
- 1 - 9 Light Steel Door
- 40 Year Metal Roofing + Cupola
- 10' Walls + 8' Lean-to
- Half Loft & Steps with Landing
- Awning

Estimated Price **\$87,200**  
+ Foundation & Concrete \$14,000 - \$19,000



## BASE PRICE UNIT

HOW IT'S BUILT

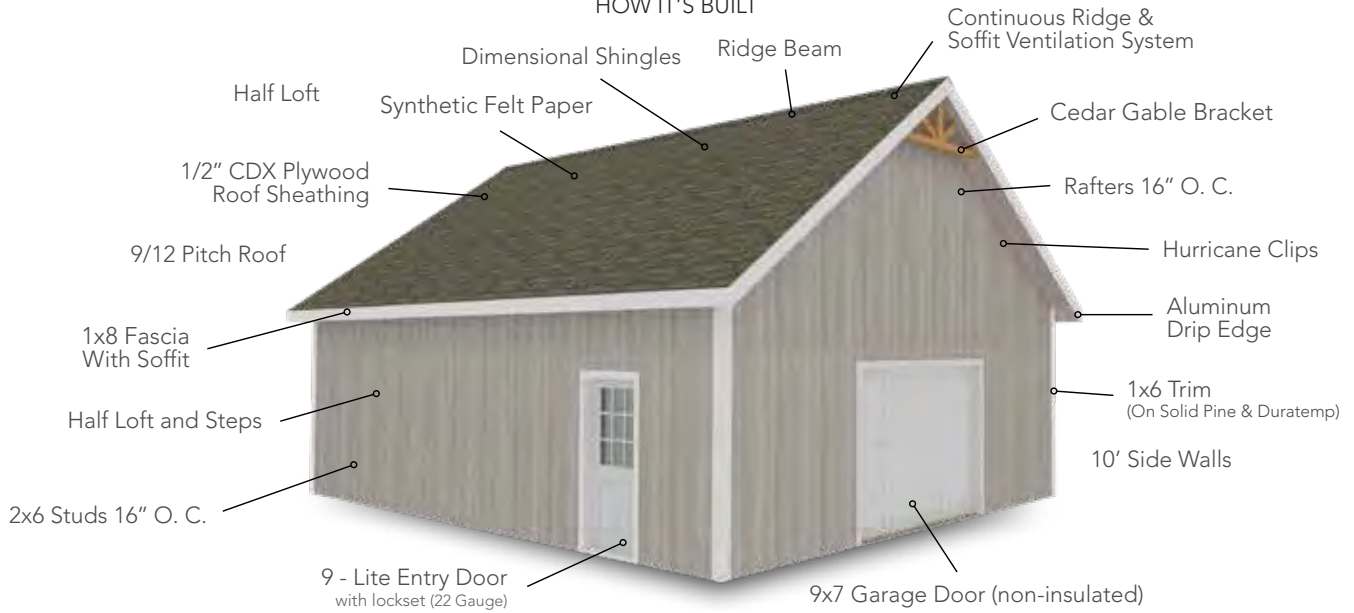

### INFORMATION

\*free delivery for 30 miles, delivery charges may apply beyond 30 Miles

The Willow Creek is real property No additional sales tax charged

Floor is not included

### BUILDING HEIGHTS

20' Wide = 18' 2" High  
 24' Wide = 19' 8" High  
 30' Wide = 21' 11" High



## SIDING CHOICES View Pricing Guide For Current Pricing

### SMARTSIDE LAP SIDING

- 50 YEAR LIMITED WARRANTY**
- Natural Wood Grain Texture
  - 100% Clear
  - Pre-Primed
  - 50 Year Limited Warranty



### VINYL SIDING

- Maintenance Free
- .044 Thickness
- Match Your Home
- CDX Plywood Subsidizing



### PINE SIDING

- 1 x 8 Premium Grade Pine Siding
- Exclusive Rough Sawn Finish
- Aesthetically Pleasing
- Tongue & Groove



### BOARD & BATTEN

- 50 YEAR LIMITED WARRANTY**
- Natural Wood Grain Texture
  - 100% Clear
  - Pre-Primed
  - 50 Year Limited Warranty



### DURATEMP SIDING

- 50 YEAR LIMITED WARRANTY**
- Natural Wood Grain Texture
  - 100% Clear
  - Pre-Primed
  - 50 Year Limited Warranty



### SMARTSIDE SIDING

- 50 YEAR LIMITED WARRANTY**
- Natural Wood Grain Texture
  - 100% Clear
  - Pre-Primed
  - 50 Year Limited Warranty



# Cascade

## OPTIONS ON THIS 24x32

- Black Metal Roofing
- Custom Window Package
- 32' Awning
- 10x8 #360 Full Glass Garage Doors
- Painted Full Glass Entry Door
- SW Iron Ore / Black / Pecan



## CASCADE ESTIMATE MATRIX



### Two Car Basic

- Size: 20 x 24
- Painted LP Lap Siding
- Metal Roof
- 1 - 16x8 5000 Series Garage Door
- 1 - Full Glass Entry Door

Estimated Price **\$46,800**  
 + Foundation & Concrete \$9,000 - \$13,000



### Two Car Deluxe

- Size: 24x32
- Painted LP Siding (*Lap and Board & Batten*)
- 2 - 18x60 Black Vinyl Window
- 2 - 18x40 Black Vinyl Window
- 2 - 18x28 Black Vinyl Window
- 2 - 10x8 #360 Full Glass Garage Doors
- Full Glass Entry Door
- Legacy Panel Metal Roof
- 32' Timber Awning

Estimated Price **\$78,100**  
 + Foundation & Concrete \$12,000 - \$16,000



### Three Car Deluxe

- Size: 24x40
- Painted LP Siding (*Lap and Board & Batten*)
- 3 - 20x108 Black Vinyl Window
- 1 - 36x50 Black Vinyl Window
- 3 - 10x8 #360 Full Glass Garage Doors
- Stained Fiberglass Entry Door
- Legacy Panel Metal Roof
- 40' Timber Awning

Estimated Price **\$95,300**  
 + Foundation & Concrete \$18,000 - \$21,000



## BASE PRICE UNIT

HOW IT'S BUILT

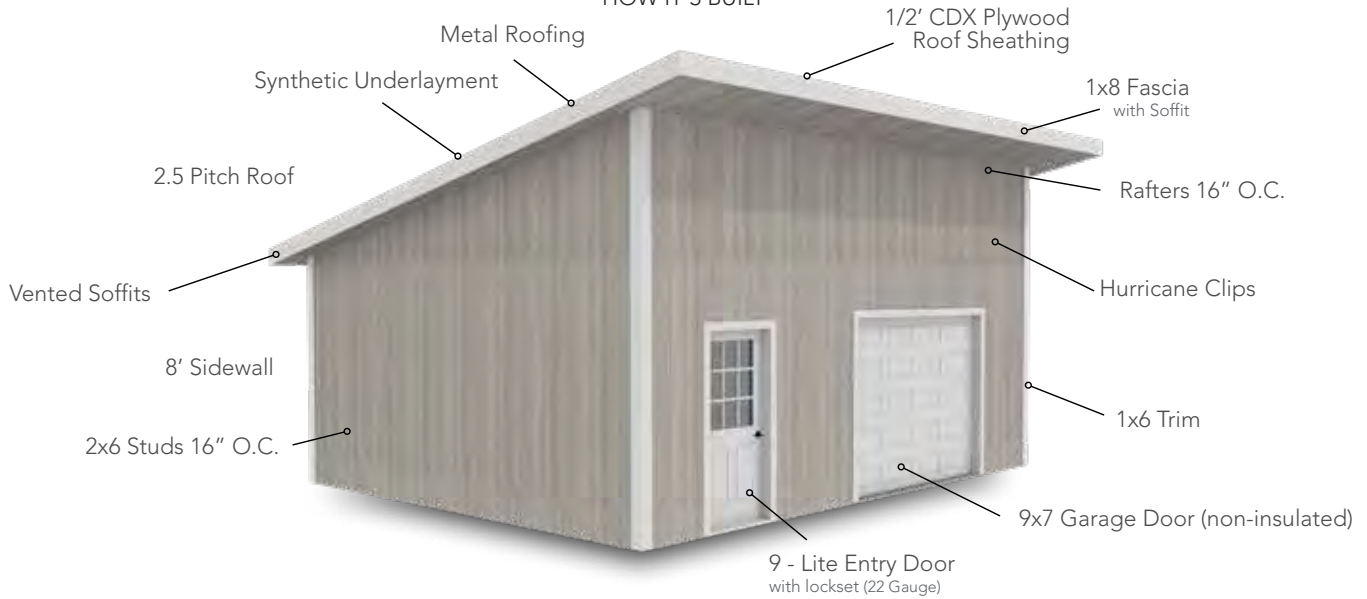

### INFORMATION

\*free delivery for 30 miles, delivery charges may apply beyond 30 Miles

The Cascade is real property No additional sales tax charged

Floor is not included

### BUILDING HEIGHTS

20' Wide = 14' 1" High  
 24' Wide = 14' 11" High  
 28' Wide = 15' 9" High



## SIDING CHOICES [View Pricing Guide For Current Pricing](#)

### SMARTSIDE LAP SIDING

- 50 YEAR LIMITED WARRANTY
- Natural Wood Grain Texture
- 100% Clear
- Pre-Primed
- 50 Year Limited Warranty



### VINYL SIDING

- Maintenance Free
- .044 Thickness
- Match Your Home
- CDX Plywood Subsidizing



### PINE SIDING

- 1 x 8 Premium Grade Pine Siding
- Exclusive Rough Sawn Finish
- Aesthetically Pleasing
- Tongue & Groove



### BOARD & BATTEN

- 50 YEAR LIMITED WARRANTY
- Natural Wood Grain Texture
- 100% Clear
- Pre-Primed
- 50 Year Limited Warranty



### DURATEMP SIDING

- 50 YEAR LIMITED WARRANTY
- Natural Wood Grain Texture
- 100% Clear
- Pre-Primed
- 50 Year Limited Warranty



### SMARTSIDE SIDING

- 50 YEAR LIMITED WARRANTY
- Natural Wood Grain Texture
- 100% Clear
- Pre-Primed
- 50 Year Limited Warranty



# Dutch Garage

## OPTIONS ON THIS 24x32

- Legacy Black Metal Roof
- 3' x 4' SH Vinyl Window
- 2' x 3' SH Vinyl Window
- Shutter Sets
- Cedar Vent
- 20' Open Rafter Awning
- 16' x 8' Garage Door
- 10' x 8' Sliding Barn Doors
- 6' French Doors, Painted
- 9' Sidewall
- White/Pecan



## DUTCH GARAGE ESTIMATE MATRIX



### Two Car Basic

- Size: 24 x 24  
 Painted Smartside Siding  
 1 - 16 x 8 Non-Insulated Garage Door  
 1 - 9 Light Steel Door  
 1 - 3 x 4 Vinyl Window  
 1 - 2 x 3 Vinyl Window  
 Cedar Shutters  
 9' Sidewall  
 Attic Truss + Loft + Pull Down Steps  
 Dimensional Shingles

Estimated Price **\$41,200**  
 + Foundation & Concrete \$9,000 - \$14,000



### Two Car Deluxe

- Size: 24 x 28  
 Painted Duratemp Siding  
 2 - 9 x 8 Carriage House Doors  
 1 - 72" Full Glass Steel Doors  
 1 - 10 x 8 Cedar Sliding Barn Doors  
 Open Rafter Awning  
 1 - 2 x 4 Vinyl Window  
 Shutter Set  
 9' Sidewalls  
 3' Stone Wainscot (2 sides)  
 Legacy Panel Metal Roof  
 Attic Truss + Loft + Pull Down Steps

Estimated Price **\$59,900**  
 + Foundation & Concrete \$12,000 - \$16,000



### Three Car Deluxe

- Size: 24 x 36  
 Painted Board & Batten Siding  
 2 - 9 x 8 Carriage House Doors  
 1 - 72" Full Glass Steel Doors  
 1 - 10 x 8 Cedar Sliding Barn Doors  
 Open Rafter Awning  
 1 - 3 x 4, 2 x 4 Window  
 Shutter Sets  
 9' Sidewalls  
 3' Stone Wainscot (2 Sides)  
 Legacy Panel Metal Roof  
 Attic Truss With Steps and Landing + Railing

Estimated Price **\$77,500**  
 + Foundation & Concrete \$13,000 - \$19,000

# Dutch Garage



## BASE PRICE UNIT

HOW IT'S BUILT

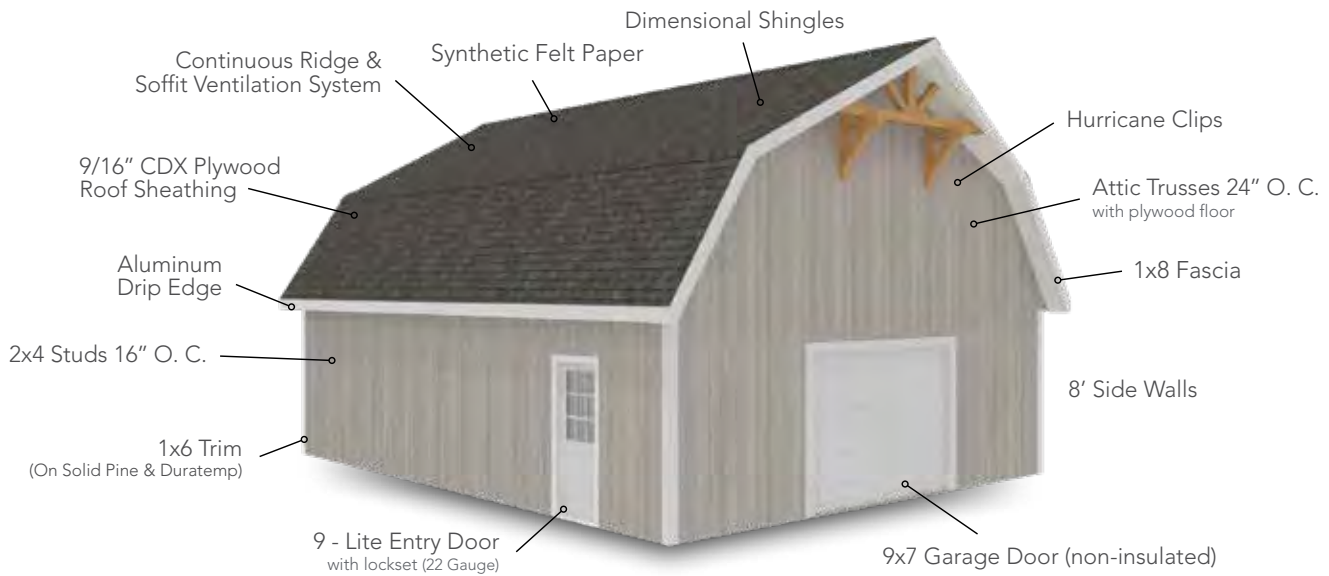

### INFORMATION

\*free delivery for 30 miles, delivery charges may apply beyond 30 Miles

The Dutch is real property No additional sales tax charged

Floor is not included

**BUILDING HEIGHTS**  
 20' Wide = 17' 8" High  
 24' Wide = 19' 8" High



## SIDING CHOICES [View Pricing Guide For Current Pricing](#)

### SMARTSIDE LAP SIDING

- 50 YEAR LIMITED WARRANTY
- Natural Wood Grain Texture
- 100% Clear
- Pre-Primed
- 50 Year Limited Warranty



### VINYL SIDING

- Maintenance Free
- .044 Thickness
- Match Your Home
- CDX Plywood Subsidizing



### PINE SIDING

- 1 x 8 Premium Grade Pine Siding
- Exclusive Rough Sawn Finish
- Aesthetically Pleasing
- Tongue & Groove



### BOARD & BATTEN

- 50 YEAR LIMITED WARRANTY
- Natural Wood Grain Texture
- 100% Clear
- Pre-Primed
- 50 Year Limited Warranty



### DURATEMP SIDING

- 50 YEAR LIMITED WARRANTY
- Natural Wood Grain Texture
- 100% Clear
- Pre-Primed
- 50 Year Limited Warranty



### SMARTSIDE SIDING

- 50 YEAR LIMITED WARRANTY
- Natural Wood Grain Texture
- 100% Clear
- Pre-Primed
- 50 Year Limited Warranty



# Dutch Barn

## OPTIONS ON THIS 24x32

10' x 7' Double Sliding Door w/ Transoms  
 Loft door w/ Transom  
 Onyx Black Dimensional Shingles  
 Painted Steel Entry Door

Custom Cupola  
 Mountain Red / White  
 2' x 3' Windows  
 6' Lean to



## DUTCH BARN ESTIMATE MATRIX



### Basic Barn

Size: 20 x 24  
 Painted Smartside Siding  
 1 - 16 x 7 Insulated Garage Doors  
 1 - 9 Light Steel Door  
 Painted Door  
 Dimensional Shingle Roof  
 9' Walls  
 Half Loft With Steps & Landing

Estimated Price **\$36,900**  
 + Foundation & Concrete \$9,000 - \$13,000



### Deluxe Barn

Size: 24 x 32  
 Painted Smartside Siding  
 2 - 9 x 7 Insulated Carriage Doors  
 3 - 3 x 4 Vinyl Window  
 1 - 9 Light Steel Door  
 Dimensional Shingle Roof  
 9' Walls  
 Half Loft & Steps with Landing  
 8' Lean-to

Estimated Price **\$62,800**  
 + Foundation & Concrete \$12,000 - \$16,000



### Ultimate Barn

Size: 24 x 36  
 Painted Duratemp Siding  
 2 - 9 x 7 Insulated Carriage Doors  
 8 - 3 x 4 Vinyl Window  
 1 - 9 Light Steel Door + Loft Door  
 40 Year Metal Roof + Cupola  
 9' Walls  
 Half Loft & Steps with Landing  
 8' Lean-to

Estimated Price **\$77,800**  
 + Foundation & Concrete \$14,000 - \$19,000



# Dutch Barn

Garages



## BASE PRICE UNIT

HOW IT'S BUILT



### INFORMATION

*\*free delivery for 30 miles, delivery charges may apply beyond 30 Miles*

The Dutch is real property No additional sales tax charged

Floor is not included

#### BUILDING HEIGHTS

20' Wide = 16' 2" High  
24' Wide = 17' 8" High  
30' Wide = 19' 11" High



## SIDING CHOICES [View Pricing Guide For Current Pricing](#)

### SMARTSIDE LAP SIDING

- 50 YEAR LIMITED WARRANTY
- Natural Wood Grain Texture
- 100% Clear
- Pre-Primed
- 50 Year Limited Warranty



### VINYL SIDING

- Maintenance Free
- .044 Thickness
- Match Your Home
- CDX Plywood Subsidizing



### PINE SIDING

- 1 x 8 Premium Grade Pine Siding
- Exclusive Rough Sawn Finish
- Aesthetically Pleasing
- Tongue & Groove



### BOARD & BATTEN

- 50 YEAR LIMITED WARRANTY
- Natural Wood Grain Texture
- 100% Clear
- Pre-Primed
- 50 Year Limited Warranty



### DURATEMP SIDING

- 50 YEAR LIMITED WARRANTY
- Natural Wood Grain Texture
- 100% Clear
- Pre-Primed
- 50 Year Limited Warranty



### SMARTSIDE SIDING

- 50 YEAR LIMITED WARRANTY
- Natural Wood Grain Texture
- 100% Clear
- Pre-Primed
- 50 Year Limited Warranty





# Frontier CABIN

## OPTIONS

Smoke / Black / Deep Ruby  
6' Timber Porch  
10' Sidewalls  
Clay Window Package

ON THIS 16x24 | 576 Sq Ft.  
9-Lite & 15-Lite Steel Doors, Painted  
14' Shed Dormers, Front & Back  
2x4 Interior Wall Framing  
Galvalume Metal Roofing

## BASE PRICE UNIT

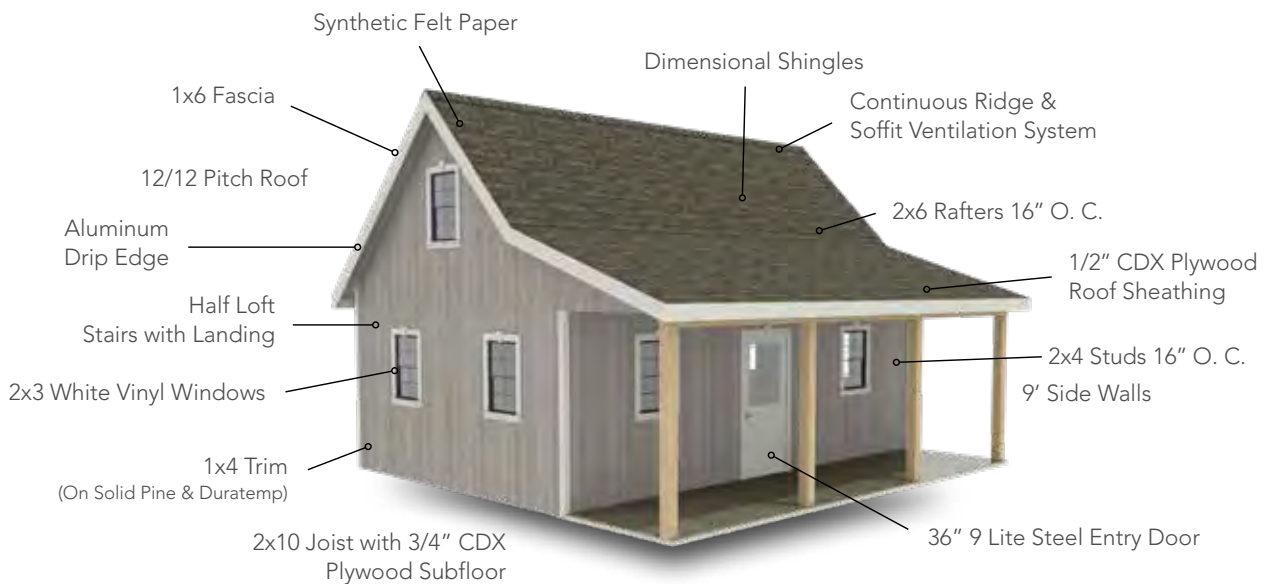

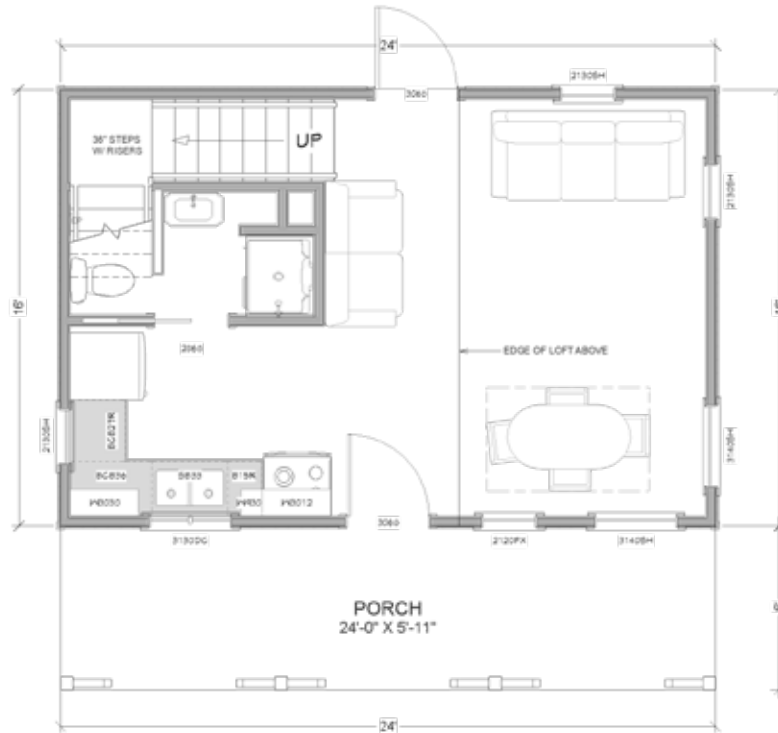

**Main Floor**



**2nd Floor**





# Aspen CABIN

**OPTIONS**  
 ON THIS 20x26 | 520 Sq Ft.  
 Black Window Package  
 Interior Wall Framing

## BASE PRICE UNIT



## Floorplan

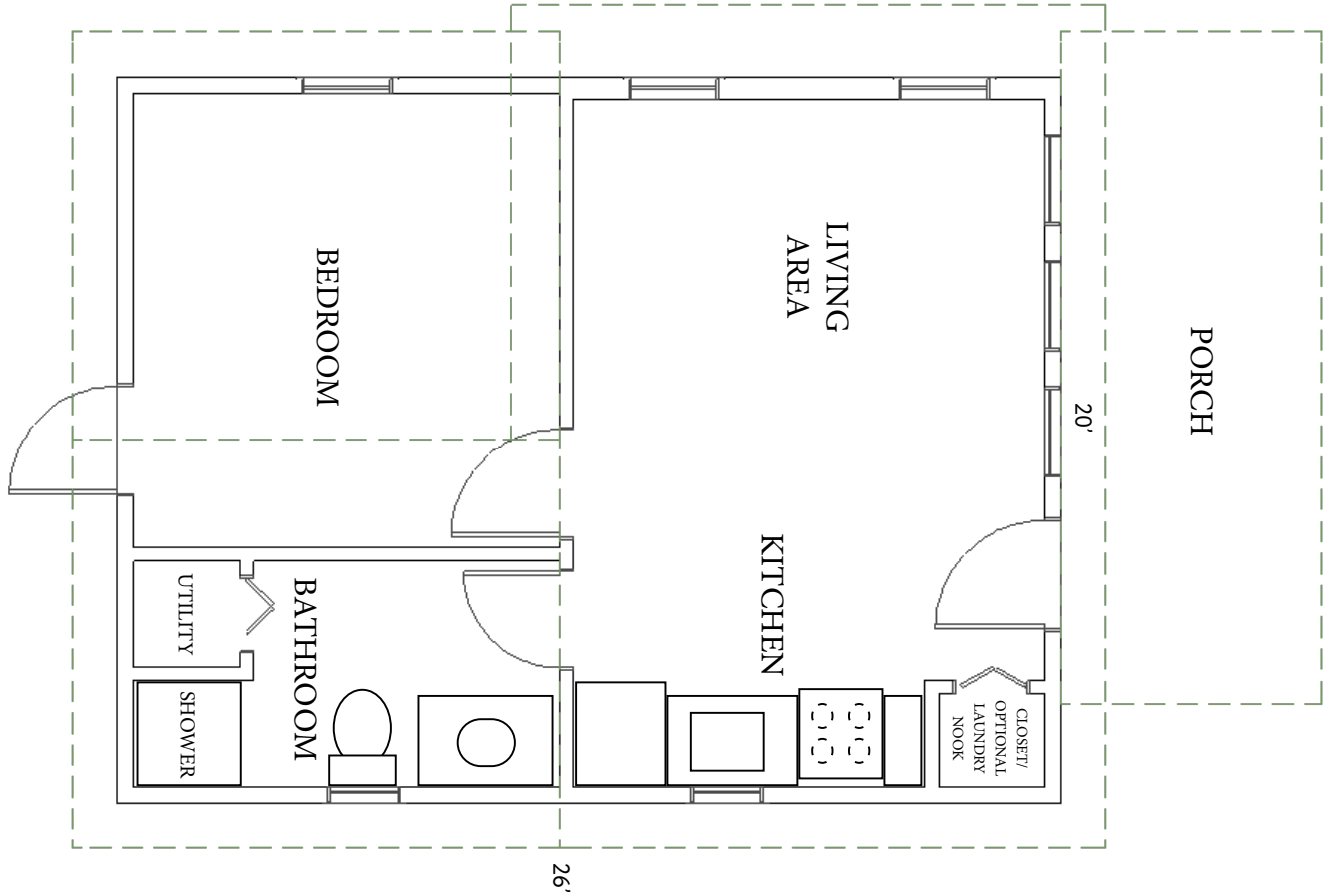



## Custom Homes & SPECIAL PROJECTS

At Weaver Barns we pride ourselves in our ability to build many different types of projects. Our clients come to us with a wide variety of unique requests and with our highly skilled team of craftsman we turn these dreams into reality. Talk to us about your custom dream project.



# Rocky Ridge | Homes

Size 20 x 32 960 Sq. Ft.



MAIN FLOOR

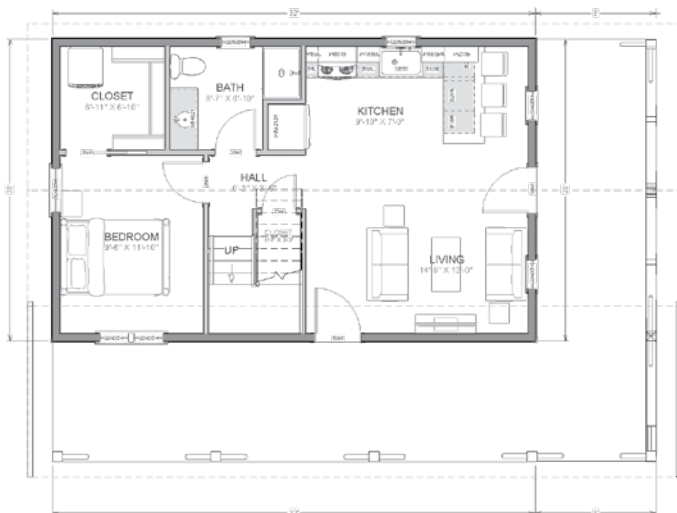

SECOND FLOOR

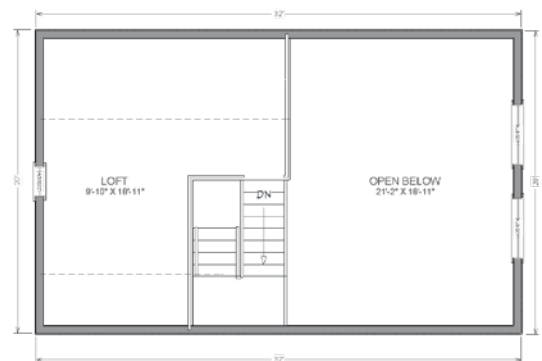

# Cedar Brooke

Homes

Size 26 x 36 1404 Sq. Ft.



MAIN FLOOR



SECOND FLOOR





# Cedar Brooke

Homes

Size 26 x 36 1512 Sq. Ft.

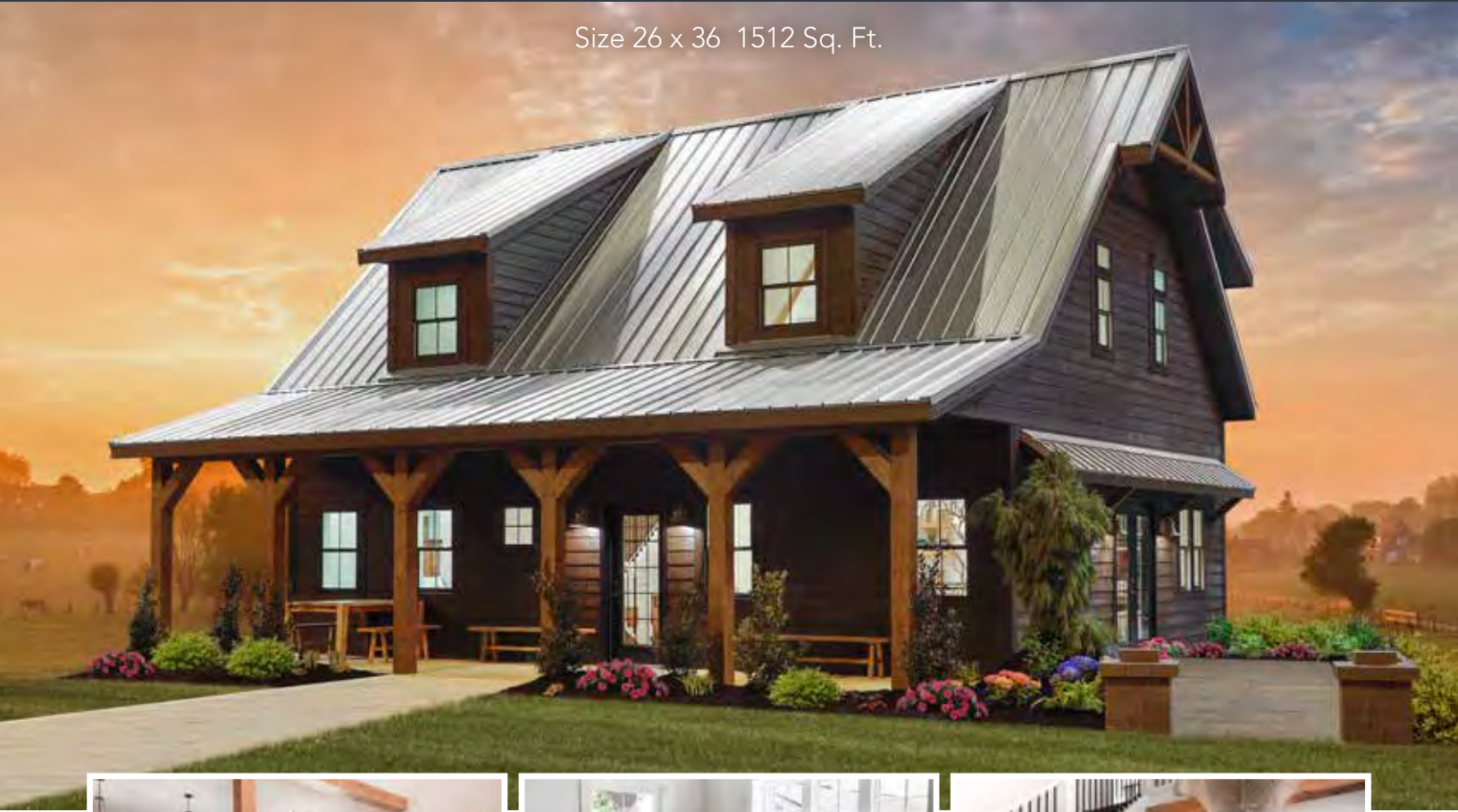

MAIN FLOOR



SECOND FLOOR



visit us online at [www.weaverbarns.com](http://www.weaverbarns.com)

# Timber Lodge

Homes

Size 24 x 36 1296 Sq. Ft.



MAIN FLOOR

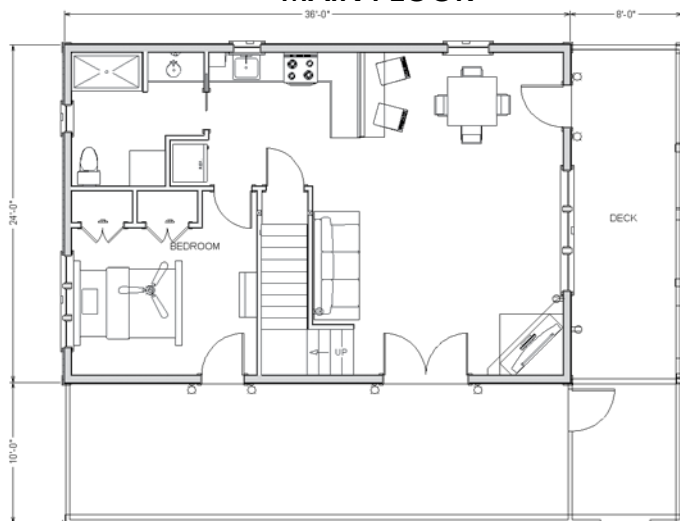

SECOND FLOOR

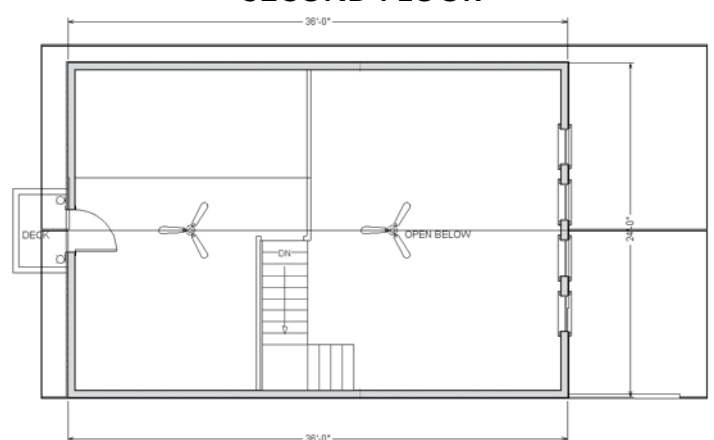

# Grand Lake | Homes

Size 32 x 40 2161 Sq. Ft.



MAIN FLOOR

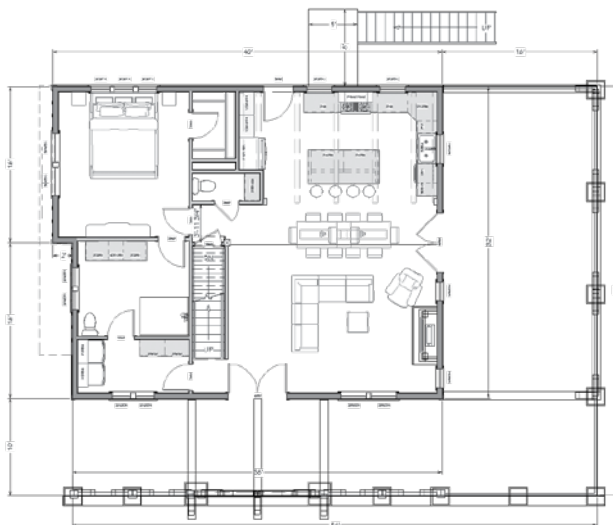

SECOND FLOOR

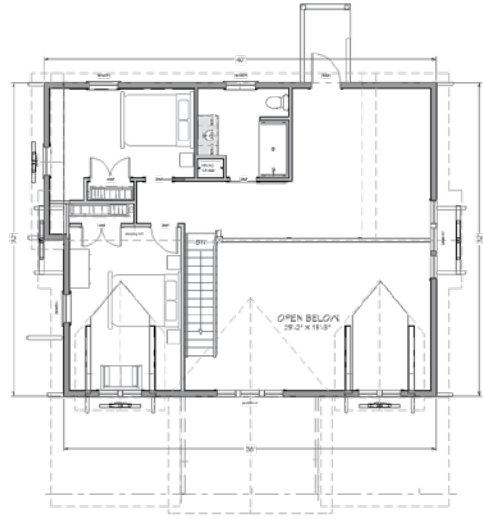

# DOORS

NOTE: Due to the effect of light, age and printing process, all color samples on these pages may vary in color or sheen from the actual materials.

## WOOD DOUBLE DOORS



#100  
SIZES - 4' 5"  
6' 7"



#102-TW  
SIZES - 4' 5"  
6' 7"



#101-SW  
SIZES - 5' 6"



#103-AW  
SIZES - 5' 6"



#200  
SIZES - 4' 5"  
6' 7"



#202-TW  
SIZES - 4' 5"  
6' 7"



#203-LW  
SIZES - 5' 6"



#204-FW  
SIZES - 5' 6"

## WOOD SINGLE DOORS



#100-SD  
SIZES - 30" 36"



#102-SD  
SIZES - 30" 36"



#101-SD  
SIZES - 30" 36"



#103-SD  
SIZES - 36"



#200-SD  
SIZES - 30" 36"



#202-SD  
SIZES - 30" 36"



#203-SD  
SIZES - 30" 36"

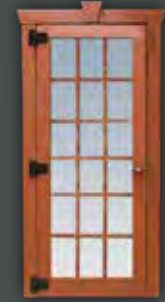

#204-SD  
SIZES - 36"

## WOOD TRIPLE DOORS



#100-TD  
SIZES 7'6" - 9'

## WOOD SLIDING DOORS



10'x7'



10'x7' with Transoms

# VINYL DOORS



#200V  
SIZES - 4' 5' 6' 7'



#200-SDV  
SIZES - 30" 36"



#202-SDV  
SIZES - 30" 36"

Optional Colors



Sandalwood

Gray

Pewter

Clay

# STEEL ENTRY DOORS

Dead Bolt +\$ Painted Steel Door + \$ Stock Grid Colors White - Black - Clay - Bronze Special Grid Colors +\$



36" 6-Panel  
ECO (no-paint)  
24 Gauge  
22 Gauge



36" 9-Lite  
ECO (no-paint)  
24 Gauge  
22 Gauge



36" 15-Lite  
22 Gauge



36" 3-Lite  
22 Gauge



72" 6-Panel  
22 Gauge

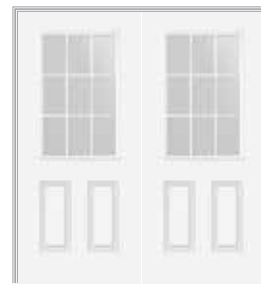

72" 9-Lite  
22 Gauge

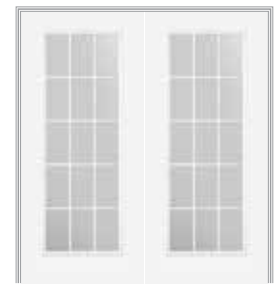

72" 15-Lite  
22 Gauge

Steel Door Colors \*Paint Is An Additional Charge



# OVERHEAD GARAGE DOORS

Garage Door Opener w/ One Remote +\$ Additional Remote +\$



Standard Door  
Available non-insulated or insulated

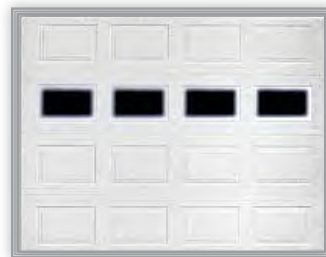

Standard Door with Optional Windows  
Available non-insulated or insulated



Carriage House Door  
Insulated



Glass Garage Door

Garage Door Colors

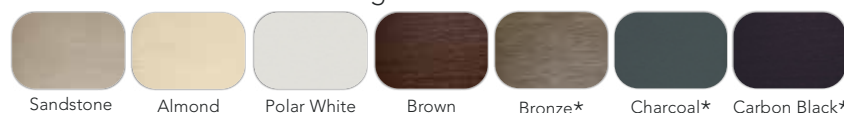

Sandstone

Almond

Polar White

Brown

Bronze\*

Charcoal\*

Carbon Black\*

\*Only available on Standard Insulated and Carriage House Doors

# DOOR RAMPS



## Door Ramps

3' depth X width of door  
 4' depth X width of door  
 5' depth X width of door  
 Ramps in Excess of 5' (per sq. ft.)



## Diamond Plate Thresholds

# DECORATIVES



Cedar Gable Vents



Peak Extension

# RAILING



1 x 4 Pine & Cedar Railing  
 \*Available In Vinyl



2 x 2 Pine & Treated Railing  
 \*Available In Vinyl

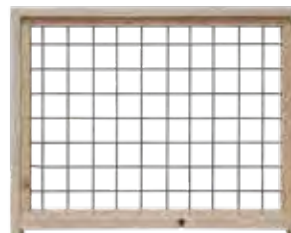

Wire Panel Railing  
 \*Interior Only



Rebar Railing  
 \*Interior Only

# STAIRS & LADDERS



Attic Ladder



**Straight Steps**  
 (1x4 Railing Upgrade Shown)  
 Add Risers Plates



**Steps With Landing & Handrail**  
 (Standard 2x2 Railing Shown)  
 Add Risers Plates



**Exterior Treated Steps**  
 3 treads  
 Steps & Landing, Cedar Railing  
 Additional Tread  
 Exterior treated landing



**Sliding  
 Stair Ladder**

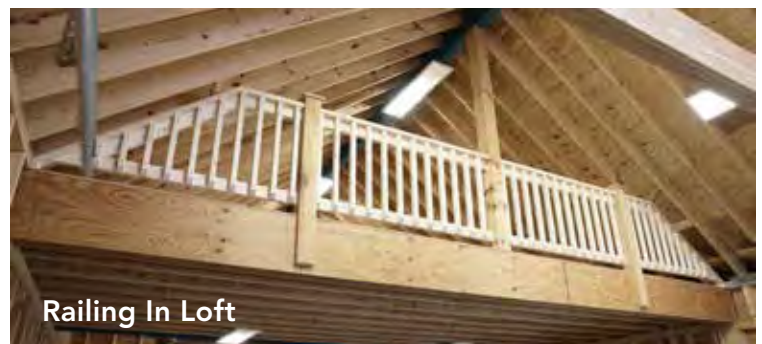

**Railing In Loft**

# WINDOWS

## ALUMINUM SINGLE HUNG WINDOWS

Includes Screens & Grids - Choose: White/Brown/Black



AVAILABLE COLORS

## VINYL WINDOWS

Includes Screens & Grids - Color: White Upgrade: Almond, Black, Clay Mulled Window

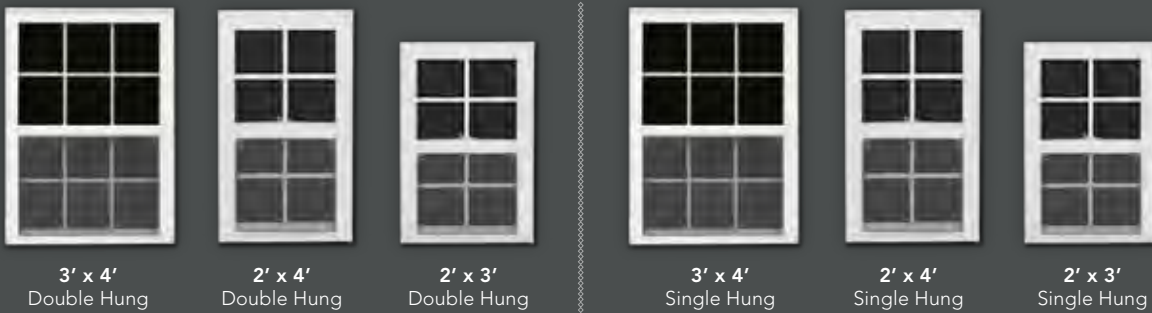

AVAILABLE COLORS

## ACCENT WINDOWS & SKYLIGHTS



**Octagon**  
White/Brown



**Aluminum Transom**  
White/Brown



**Vinyl Transom**  
White

2'x4' SKYLIGHT  
Insulated

## WOOD PANEL STYLE SHUTTERS



**K Panel Shutter**



**Plain Panel Shutter**

## WOOD/VINYL SHUTTERS & FLOWER BOXES

### WOOD



**Wood Shutters & Flower Box**

**Wood Shutters**

**Wood Shutters  
Z Strap**

**Wood Flower Box**

### VINYL



**Vinyl Shutters & Flower Box**

**Vinyl Shutters**

**Vinyl Flower Box**

# CUPOLAS & WEATHERVANES



24"

32"

40"

## Traditional Cupola

SOLID CEDAR + BRONZE METAL ROOF Standard



24"

32"

40"

## Windowpane Cupola

SOLID CEDAR + BRONZE METAL ROOF Standard  
\*Frosted Plexi-Glass Standard, Clear Available

## LARGE WEATHERVANE

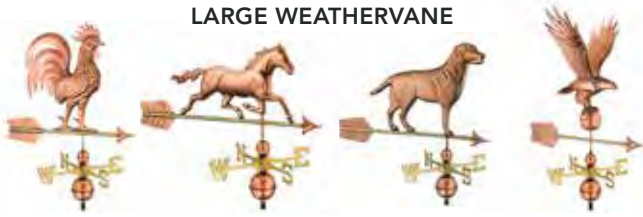

Rooster

Horse

Dog

Eagle

## SMALL WEATHERVANE



Rooster

Horse

Dog

Eagle

## ROOFING COLORS



Galvalume



Bronze



Black

## CUPOLA OPTIONS

Colored Metal Roof

110V Light inside Cupola

# SHELVES & WORKBENCHES

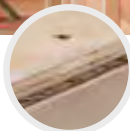

Beveled

## 1' DEPTH

8' x 1' (2 x 4 Joists)

10' x 1' (2 x 4 Joists)

12' x 1' (2 x 4 Joists with Center Post)

14' x 1' (2 x 4 Joists with Center Post)

16' x 1' (2 x 4 Joists with Center Post)

## 2' DEPTH

8' x 2' (2 x 4 Joists)

10' x 2' (2 x 4 Joists)

12' x 2' (2 x 4 Joists with Center Post)

14' x 2' (2 x 4 Joists with Center Post)

16' x 2' (2 x 4 Joists with Center Post)



Beveled

## WORKBENCH (FREESTANDING)

8' x 2'

10' x 2'

12' x 2'

# STANDARD LOFTS & CUSTOM LOFTS

## STANDARD SIZES

8' x 4' (2 x 4 Joists 16" O.C.)

10' x 4' (2 x 4 Joists 16" O.C.)

12' x 4' (2 x 6 Joists 16" O.C.)

14' x 4' (2 x 8 Joists 16" O.C.)

16' x 4' (2 x 8 Joists 16" O.C.)

## CUSTOM SIZES

2 x 8 with 5/8" plywood (per sq. ft.)

2 x 10 with 3/4" plywood (per sq. ft.)

I-joists with 3/4" plywood (per sq. ft.)





# AWNINGS & ARBORS

\*Min. 7/12 Pitch Required



## Shed Awnings

Door Awning for Man Door (56")  
(open ceiling)  
Door Awning for Garage Door (22')  
(flat ceiling)



## Door Arbors

Door Arbor for 4' Door  
Door Arbor for 5' Door  
Door Arbor for 6' Door



## Easton Awning

Door Arbor for 4' Door  
Door Arbor for 5' Door  
Door Arbor for 6' Door



Open Rafter Awning



Closed Rafter Awning

# ROOF PITCH

Sheds Steeper Roof Pitch (up to 8/12 Pitch)

(per sq. ft. X 1 pitch increase)

Sheds Steeper Roof Pitch (9/12 to 12/12 Pitch)

(per sq. ft. X 1 pitch increase)

Large Structures Steeper Roof Pitch (up to 7/12 Pitch)

(per sq. ft. X 1 pitch increase)

*\*Ask Your Sales Representative for 8/12 & Higher Pitch Prices*



# SIDEWALLS

## SHEDS & BARNs

1' increments per perimeter foot

Duratemp Buildings

Pine Buildings

Vinyl Buildings

## PAVILIONS

Per Post Per Foot Up To 10'

## CABINS, GARAGES & HOMES

1' increments per perimeter foot

Duratemp Buildings

Pine Buildings

Vinyl Buildings

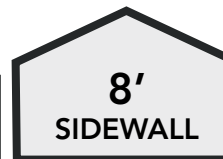

# TRIM STYLES



CRAFTSMAN  
\*STANDARD STYLE



SQUARE CUT

# GABLE BRACKETS



Timber Frame Bracket

# SHINGLES

15# Felt Paper (per sq. ft.) +\$

## STANDARD DIMENSIONAL



## OPTIONAL DURATION



# OPTIONAL METAL ROOF



*NOTE: Due to the effect of light, age and printing process, all color samples on these pages will vary in color or sheen from the actual materials.*

**METAL ROOF** (per sq. ft.)  
 Manchester & Craftsman (per sq. ft.)  
 Large Structures (per sq. ft.)  
 Dutch & Cumberland (per sq. ft.)  
 Legacy Panel Upgrade (per sq. ft.)  
 Textured Panel Upgrade (per sq. ft.)

# VINYL SIDING COLORS

## STANDARD COLORS



## PREMIUM COLORS



➤ *Ask about our additional colors available for vinyl*

# PAINT COLORS

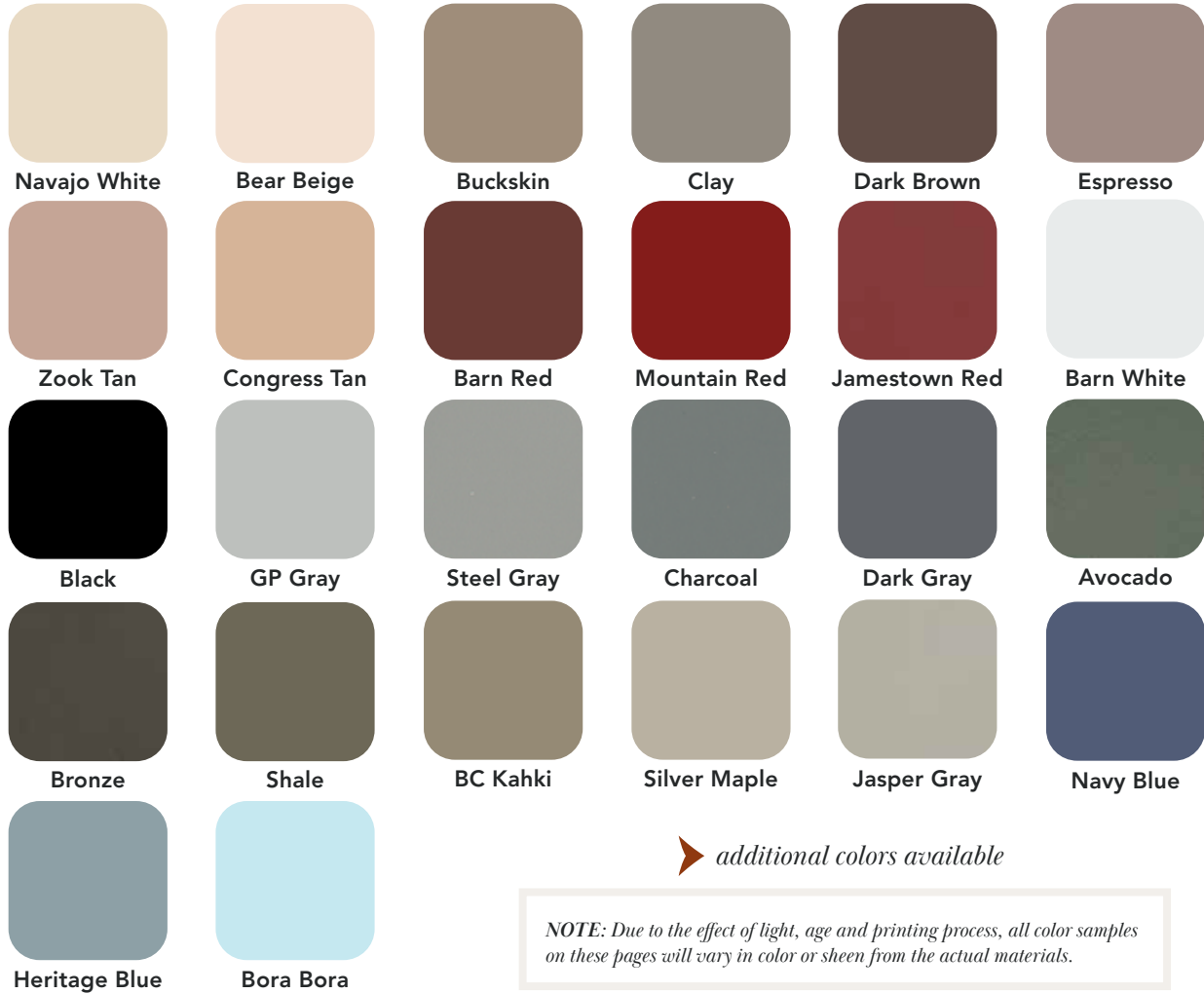

# STAIN COLORS

## PINE SIDING stain colors



## ENGINEERED SIDING stain colors





# Weaver Barns *ltd.*

"everyone needs a little structure in their life"

1696 St. Rt. 39 • Sugarcreek, Ohio 44681  
2 miles West of Sugarcreek on St. Rt. 39  
p: 330-852-2103 • Toll Free: 888-289-4940  
f: 330-852-7804 • info@weaverbarns.com

## 7 YEAR LIMITED WARRANTY

IF ANYTHING GOES WRONG OR IF WE DID SOMETHING WRONG WE WILL TAKE CARE OF IT

EXCLUSIONS: ACTS OF GOD, IMPROPER MAINTENANCE, USER DAMAGE, PAINT & STAIN, SEASONAL SETTLING, SHINGLE BLOW-OFFS DUE TO WIND

\*ON SIGNATURE MODELS

2024



Like Us  
on Facebook



Follow Us  
on Pinterest



Find Us  
on Houzz



Follow Us  
on Instagram

[www.weaverbarns.com](http://www.weaverbarns.com)